



南大傲拓科技  
Nanda Automation Technology

# NA300产品说明书



# CONTENT

<b>0 Preface</b> .....	- 3 -
<b>1 Hardware System Overview</b> .....	7
1.1 Component and Structure of NA300 Hardware System.....	8
1.2 Technical Features of NA300 .....	8
1.3 NA300 System Specifications .....	9
1.4 Product List of NA300.....	11
1.5 Hardware System Configuration of NA300 .....	13
1.5.1 Power Capacity Check and Configuration .....	13
1.5.2 Network connection .....	14
1.5.3 NA300 Software Support.....	15
<b>2 CPU Modules</b> .....	19
2.1 Basic CPU 301-0101 .....	20
<b>3 Power supply module</b> .....	27
3.1 Power supply module PWM301-24VDC.....	27
3.2 N+1 Redundant Power supply module: PWM301-0403.....	29
<b>4 Digital I/O Module</b> .....	33
4.1 Digital input module DIM301-1601: DI16×DC24V.....	34
4.2 Digital input module DIM301-3201: DI32×DC24V.....	39
4.3 Sequence of Event (SOE) Module IIM301-1601: IIM16×DC24V.....	43
4.4 Sequence of Event (SOE) Module IIM301-3201: IIM32×DC24V.....	48
4.5 Digital output module DOM301-1601: DO16×DC24V×Transistor.....	53
4.6 Digital output module DOM301-3201: DO32×DC24V×Transistor.....	57
<b>5 Analog I/O Module</b> .....	63
5.1 Analog Input module AIM301-0801: AI8×current/voltage.....	63
5.2 Analog Input module AIM301-0805: AI8×RTD .....	67
5.3 Analog Input module AIM301-0806: AI8×thermocouple.....	71
5.4 Analog Input module AIM301-1602: AI16×current type.....	76
5.5 Analog Output module AOM301-0401: AO4×current/voltage.....	- 80 -

<b>6 High Speed Count Module</b> .....	- 88 -
6.1 High-Speed Count Module HCM301-0302.....	- 88 -
6.2 High-Speed Count Module HCM301-0801.....	- 95 -
<b>7 Communication Module</b> .....	- 105 -
7.1 Serial Communication Module CMM301-0401 .....	- 106 -
7.2 Profibus DP Slave Communication Module CMM301-0103.....	- 111 -
7.3 Double CAN Module CMM301-0204.....	- 116 -
7.4 Ethernet Substation CMM301-0118 .....	- 121 -
7.5 Profinet Slave Communication Module CMM301-0109 .....	- 128 -
7.6 CANOpen Master Module CMM 301-0104 .....	- 135 -
<b>8 NA300 System Configuration</b> .....	- 140 -
8.1 How to choose I/O modules.....	- 140 -
8.2 How to choose CPU.....	- 141 -
8.3 How to choose backplane.....	- 143 -
8.3.1 Backplane type.....	- 143 -
8.3.2 Main features of backplane .....	- 143 -
8.3.3 Bus Expansion.....	- 144 -
<b>9 Hardware Mounting</b> .....	- 147 -
9.1 The Mounting of Module Backplane.....	- 147 -
9.2 Mounting of the module.....	- 148 -
<b>10 Accessories</b> .....	- 150 -

## 0 Preface

The NA series Programmable Logic Controllers (NA-PLC) are designed and developed independently by Nanda Automation Technology Co., Ltd. NA-PLC draws on the successful experiences of the international main stream PLCs to improve their deficiencies, aims at the latest development of today's PLC, and adopts a combined world-leading advanced technologies in information, communication,electronics, automatic control technology and other areas. From the aspects of operating system, CPU, I/O signal processing, network communication, software development and production process, NA-PLC has a superior performance and is suitable for all kinds of automatic control. NA300 PLC has greatly enhanced traditional PLC functions, including flexibility in networking, degree of opening in system platform, flexibility in programming software and module intelligence, so that the control of complex projects can be realized perfectly.

More features about NA300 PLC are as follows:

### ■ **Stable and Reliable**

- Entire intelligent I/O and a series design in security, reliability provide the system with a strong guarantee for its' safe and secure operation.
- Low-power consumption design is adopted in which CPU module power consumption is about 2.5W and I/O module power consumption is about 2W.
- Hot swapping /hot plugging are supported, so that replacing or adding

components do not require significant interruption to the system and there will be no interference to other input and output.

- CPU boundaries, I/O boundaries, communication network boundaries and Power supply are electrically isolated. These isolation boundaries are examined and approved as providing safe separation.
- Excellent electromagnetic compatibility.
- Users' program and data can be stored permanently.
- Protecting the intellectual property rights of users by using password configuration.

■ **Comprehensive functions & modules**

- Rich types of modules applying to a variety of applications, including power supply module(PWM), CPU module, communication module(CMM), digital input module(DIM), sequence of event module(SOE), digital output module(DOM), analog input module(AIM), analog output module(AOM), temperature module.
- Using embedded real-time multitasking operating system to support multi-task allocation for a better use of CPU resources.
- Open network with 100Mbps NIC with support to MODBUS/TCP protocol.
- Multiple serial communications. Supporting MODBUS and customized protocols.
- Extensive built-in integration functions, including not only standard operators,

control modules, standard functions, but also practical and cost effective functions such as PID, SOE (Sequence of Event) to meet the demand for high-end applications with low costs.

- Integrating a hardware watch-dog to give a wide range of fault monitoring and diagnosis.
- The CPU module has OLED screen to show more information about running and fault,
- AI/AO modules can show the input/output of signal in the OLED screen.
- Hardware event resolution up to 1ms.

■ **Cost effective**

- NIC is integrated in CPU module (saving communication module).
- Serial communication modules provide rich communication interfaces to work with other devices and systems.
- Expanding plug box can be done directly without additional expansion module (saving expansion module).
- Programming and debugging is quick and convenient.
- IEC61131-3 International Standard is conformed.
- Rich functions including system configuration, database configuration and more online functions such as database online query, ladder diagram online monitoring, structured text online debugging and modification, technological process online testing.

- Various programming languages such as LD, IL, ST, SCC, FBD are supported.
- English-Chinese bilingual programming makes the code more readable.
- Friendly GUI with both intelligent graphic and textual edit function.
- Remote programming and debugging through Ethernet is supported.
- More friendly and intelligent help system.

# 1 Hardware System Overview

## Synopsis

NA300 PLC is a new series of products based on years of Nanda proud extension in PLC research and development experience. Products using low-power embedded processors, fast processing, large memory, communication interface rich, NA300 PLC firstly innovatively use OLED screen technology to display, AI, AO modules display the real-time analog signal value, providing personalized solutions for different industrial areas. It can be widely used in metallurgy, building materials, light industry, transportation, power, petrochemical, automotive, mining, water treatment, food processing and other industries.

## Content

In this chapter, the following will be described:

Section	Content
1.1	Component and Structure of NA300 Hardware System
1.2	Technical Features of NA300
1.3	NA300 System Specifications
1.4	Product List of NA300
1.5	Hardware System Configuration of NA300

## 1.1 Component and Structure of NA300 Hardware System

The hardware system of NA300 series PLC consists of controller modules, sequence of events modules, general I/O modules, communication modules, backplane and system power supply. All modules are installed on the backplane.

- Controller module: also called CPU module. It is installed on the local backplane. Controller with a built-in 10/100 Mbps Ethernet and two serial communication interface. The internal bus leads through the local backplane, making it a convenient for a hot-plug operation.
- SOE module: It provides digital input signal acquisition and records the sequence of the displacement event. The resolution is 1.0ms.
- General I/O module: It can be installed in the local backplane and expansion backplane. It communicates with the controllers by high-speed internal bus.
- Communication module: It can be installed in the local backplane or the expansion backplane and used for appending other communication protocols. NA300 controller can communicate with third party devices by RS485, PROFIBUS-DP, CAN, Ethernet, PROFINET and so on. If NA300 control system is to provide a certain communication function, this can be achieved by simply installing an appropriate communication module on the backplane.
- Power supply module: It is installed in the backplane, providing power supply to other modules. The power supply to the field devices should be installed separately in order to ensure the electrical isolation between the field and the control system.

## 1.2 Technical Features of NA300

- CPU Module has 2 of its own independent serial ports with 2 independent / hot backup Ethernet interface. In addition, it can support current widely used communication protocols through communication expanding modules to interfacing with RS485, PROFIBUS-DP, CAN, Ethernet, PROFINET, and etc
- Advanced field-bus network: High speed field-bus is used for internal communication, which is of fast rate, strong anti-interference ability and ease of expansion.
- The average power consumption of CPU modules is 2.5W, and 2W for I/O modules.

- The program software NAPRO not only supports the four program languages complying with the international standard IEC61131-3, which are Ladder Diagram(LD), Instruction List(IL), Structured Text(ST), and Function Block Diagram(FBD), but also supports the Sequential Control Charts(SCC), which is the most classical language used in sequential control process.
- Algorithms for sequence, process, and motion control and other commonly used are included in the product.
- Self-diagnosis: Most commonly used I/O modules have failure self-diagnosis function which is done periodically, and will report diagnosis result to CPU modules. At the same time, Status Indicator LEDs with different colors are located on the panels of every modules, including RUN state, Fault state, and communication state, etc.. A combination of light, flicker, or off represent different running states of modules, so that one could see clear enough about the running state of every modules.
- Hot-Plugging: All the functional modules (communication modules, CPU modules and I/O modules) support hot-plugging, so that engineers could replace or repair components without significant interruption to the system when some modules failed.

### 1.3 NA300 System Specifications

Table 1. General system specifications of NA300 Hardware System:

System Power	5VDC	Supply Voltage	5VDC (-5 %, +5 %)
		Ripple	<5%
		Reverse Voltage Protection	YES
Electromagnetic Compatibility (EMC)	Immunity	Surge Immunity	IEC61000-4-5 4kV (CM) /2kV (DM)
		Oscillatory Wave Immunity	IEC61000-4-12 2.5kV (CM) /1kV (DM)
		Electrical Fast Transient	IEC61000-4-4 ±4kV (Power) /±2kV (I/O)
		Electro-Static Discharge	IEC61000-4-2 ±15kV (Air) /±8kV (Contact)
		Radiation Electromagnetic	IEC61000-4-3 10V/m, Frequency 80MHz~1GHz

		Immunity		
		Electromagnetic Radiation Interference	Radiated Interference Measure	CISPR 16-2-3 2006 30~230MHz 10m Quasi-peak value < 40dB(μV/m) 230~1000MHz 10m Quasi-peak value < 47dB(μV/m)
			Conducted Interference Measure	CISPR 16-2-1 2005 0.15~0.5MHz Quasi-peak value < 79dB(μV) Average value < 66dB(μV) 0.5~30MHz Quasi-peak value < 73dB(μV) Average value < 60dB(μV)
		Environmental Adaptation	Climatic Environment	Operating Temperature
Operating Humidity	5%~95%, non-condensing			
Operating Altitude	0~3000m			
Storage Temperature	-40 □ ~ +60 □			
Storage Humidity	5%~95%, non-condensing			
Mechanical Environment	Vibration		IEC 60068-2-6: Part 2-6/10 up 58 Hz, uniform amplitude 0.075 mm 1G (gravity acceleration), amplitude 0.3mm, Frequency 58~150Hz	
	Shock		IEC 60068-2-27: 15G, duration 11ms	
	Drop		IEC 60068-2-31: 50mm, drop 4 times (unpacked)	
	Free-Fall		IEC 60068-2-32: 1m, drop 5 times (shipping package)	
Shell Protection	Class Of Shell Protection		IEC60529 IP20 (prevent foreign articles larger than 12mm from access, but not waterproof)	

## 1.4 Product List of NA300

NA300 PLC hardware product is composed of CPU modules, communication modules, I/O modules, backplane and power supply modules. I/O modules and communication modules can be divided into several types according to the functions.

Table 2. NA300 PLC Hardware Product List:

Module Type	Order NO.	Notes
Controller CPU	300CPU3010101	Normal CPU, RS485×2(standard MODBUS), NIC×2 Ethernet (standard MODBUS/TCP),program space 8M
Digital Input	300DIM3011601	16 points input 24VDC(Two-way input)
	300DIM3013201	32 points input 24VDC (Two-way input)
Digital Output	300DOM3011601	16 points output 24VDC, transistor
	300DOM3013201	32 points output 24VDC, transistor
Sequence of Event	300IIM3011601	16 points input 24VDC(Two-way input)
	300IIM3013201	32 points input 24VDC(Two-way input )
Analog Input	300AIM3010401	4 points, Current/Voltage, Single Ended Input
	300AIM3010801	8 points, Current/Voltage, Single Ended Input
	300AIM3010405	4 points, RTD Input
	300AIM3010805	8 points, RTD Input
	300AIM3010806	Thermocouple input 8 points
Analog Output	300AOM3010201	2points, Current/Voltage
	300AOM3010401	4 points, Current/Voltage
Communication Module	300CMM3010401	4×RS485
	300CMM3010103	Profibus DP Slave
	300CMM3010204	Double CAN Module
	300CMM3010118	Ethernet Substation

	300CMM3010109	Profinet Slave
Power Supply Module	300PWM3010401	40W, external power supply 24V DC
	300PWM3010403	40W, N+1 Redundant Power supply 24V DC
Accessories	300BKM3010801	8-slot backplane
	300BKM3011201	12-slot backplane
	300CNL3010101	Communication Expanding Cable, 1m
	300CNL3010201	Communication Expanding Cable, 2m
	300CNL3010301	Communication Expanding Cable, 3m
	300NUL3010101	NULL Module
	300BUS3010101	Bus Adapter
	300CNE3013601	36-pin module connection terminal - with release lever
	300CNE3013602	36 core module connection terminal - screw fixed
	300CNE3011801	18-pin module connection terminal - with release lever
	300CNE3011802	18 core module connection terminal - screw fixed
	300CNE3012601	26-pin module connection terminal - with release lever
	300CNE3012602	26 core module connection terminal - screw fixed
	300CNE3011301	13-pin module connection terminal - with release lever
	300CNE3011302	13 core module connection terminal - screw fixed
	300CNE3011201	12-pin module connection terminal - with release lever
	300CNE3011202	12 core module connection terminal - screw fixed
	300CNE3010601	6-pin module connection terminal - with release lever
	300CNE3010602	6 core module connection terminal - screw fixed

## 1.5 Hardware System Configuration of NA300

### 1.5.1 Power Capacity Check and Configuration

For safety considerations, it is suggested that the total power consumption of all modules is less than 70% of the consumption of the selected power supply. Please see Table 3 which shows the power consumption of each module. The figure listed in Table 3 is the system consumption of NA300, which is not the output consumption of power supply (i.e. power supply for switches, load, transmitters and other field apparatus). Please refer to corresponding I/O module manuals to determine the output consumption of power supply according to different loads of each I/O channel. Special attention should be paid that field power supply should not be mixed up with system supply to avoid possible damages to NA300 hardware system and to ensure electrical isolation between the field and the control system.

Table 3. NA300 PLC Module Power Consumption List:

Module Type	Model	Voltage	Current	Power Consumption
CPU	CPU301-0101	5VDC	0.5A	2.5W
DI	DIM301-1601	5VDC	200mA	1W
	DIM301-3201	5VDC	320mA	1.6W
DO	DOM301-1601	5VDC	300mA	1.5W
	DOM301-3201	5VDC	450mA	2.25W
SOE	IIM301-1601	5VDC	200mA	1W
	IIM301-3201	5VDC	320mA	1.6W
AI	AIM301-0401	5VDC	360mA	1.8W
	AIM301-0801	5VDC	380mA	1.9W
	AIM301-0405	5VDC	400mA	2W
	AIM301-0805	5VDC	480mA	2.4W
AO	AOM301-0201	5VDC	500mA	2.5W

	AOM301-0401	5VDC	520mA	2.6W
CMM	CMM301-0401	5VDC	350mA	1.75W
	CMM301-0103	5VDC	400mA	2W
	CMM301-0204	5VDC	450mA	2.25W
	CMM301-0118	5VDC	790mA	3.95W
	CMM301-0109	5VDC	400mA	2W

## 1.5.2 Network connection

### ■ Ethernet

NA300 CPU has a built-in dual link Ethernet interface, which complies with IEEE802.3/u standard and which is 10/100Mbps self-adapted. It has the output from the front panel of CPU modules with a standard RJ45 socket. It uses shielded twisted-pair cable or non-shielded twisted-pair cable.

### ■ High-speed Internal Network

High-speed internal network(HIN) is the internal bus of NA300 PLC, which ensures the reliable control of NA300 PLC with its speediness, strong anti-interference capacity and easy expandability.

#### Features:

1. HIN of every I/O module is electrically isolated, so that one module's breakdown won't affect the communication of the other modules.
2. High speed and real-time HIN Communication has a strong capability of recognizing and processing errors.
3. There is a double line of high-speed internal field-bus network. The data exchange between CPU modules and I/O modules uses HIN1, while the data exchange between CPU modules and other modules, such as serial communication modules, uses HIN2. These two networks are separate and will not affect each other.
4. HIN is serial bus which is easy to expand and improves the flexibility of system configuration.

### ■ RS-485 Serial Communication Interface

RS-485 serial communication interface connects NA300 series PLC with external

intelligent devices. It not only saves cables and modules, but also avails inspection and maintenance.

### ■ CAN Communication Interface

CAN communication interface connects NA300 series PLC with external CAN intelligent devices. It not only saves cables and modules, but also avails inspection and maintenance.

## 1.5.3 NA300 Software Support

NA300 PLC uses NAPro software, developed solely by Nanda Automation Technology, to program the software and debug the system. NAPro software, an IEC61131-3 standardized programming, debugging and running software, can also be used with NA300 or NA300 PLC. It consists of an editor, a compiler a debugger, a simulator and GUI tools. It can be used to do hardware configuration, test point configuration, software programming, simulation, debug and download.

NAPro processes a series of full functions which makes it a good choice to improve productivity and software collaboration. With the development cost decrease and optimal operation, NAPro can ensure optimizing customer's software investment, lowering the training cost, and a peerless potential in development and compatibility.

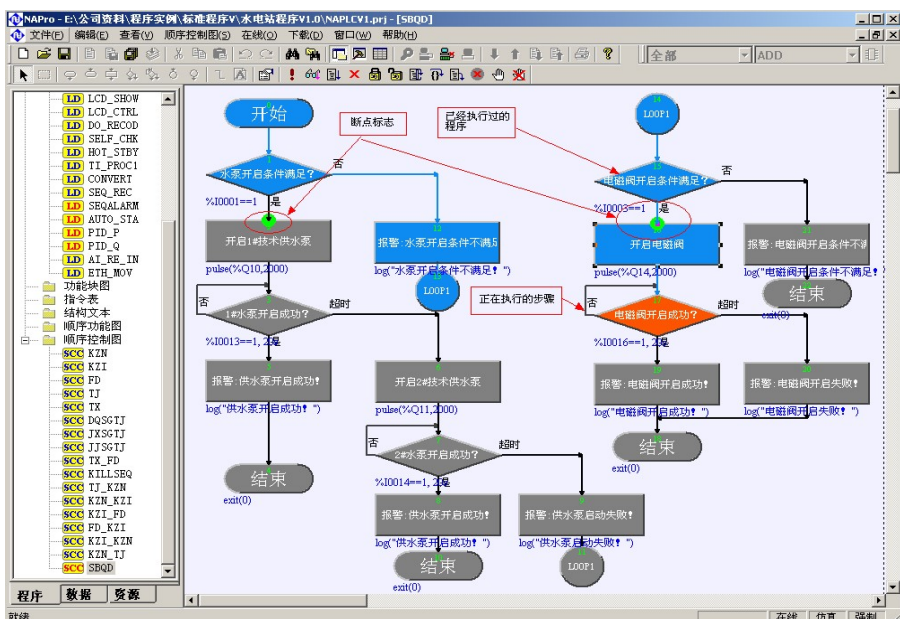

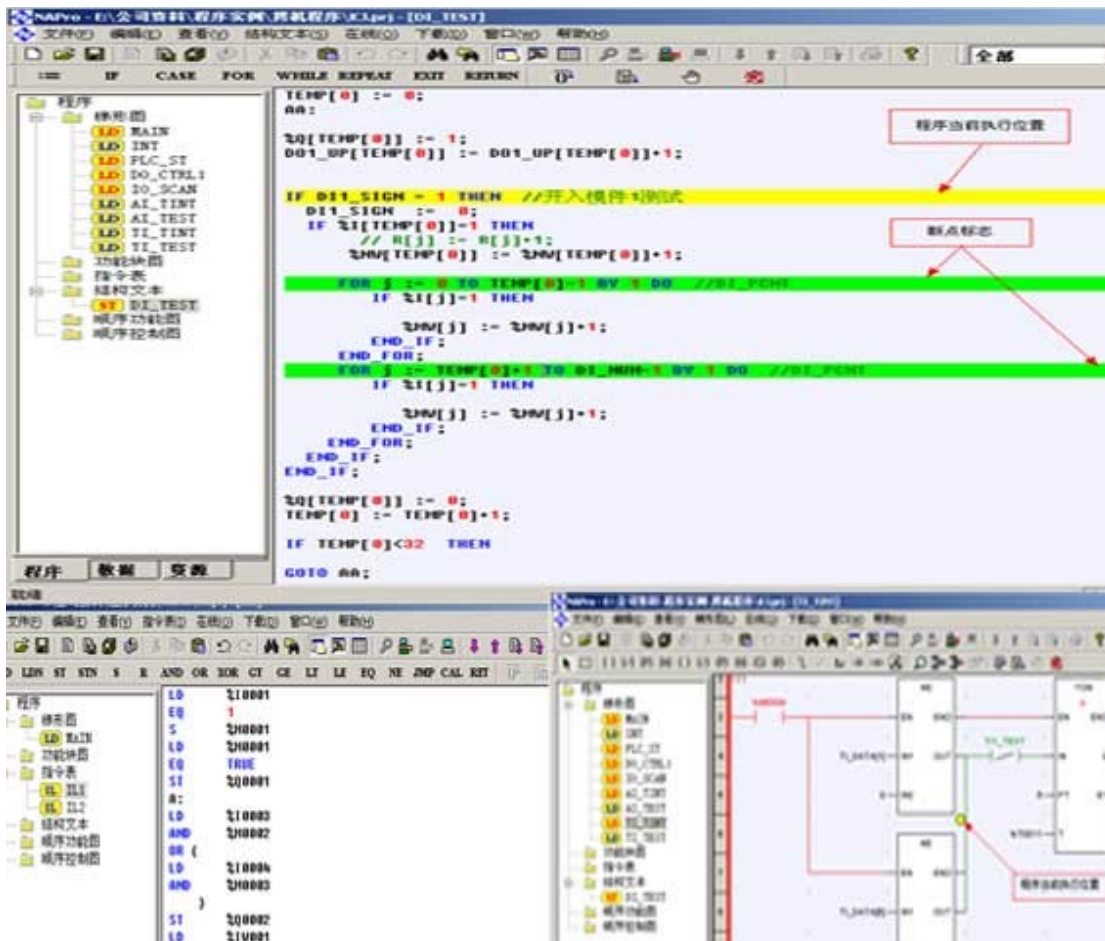

Features of NAPro programming software are as following:

### Comply with IEC-61131 international standard

NAPro complies with IEC-61131 international standard, which provides an uniform and effective system configuration environment which makes it possible for the engineers to “learn once, and use everywhere”.

### Fully support Chinese programming environment

Chinese is fully supported in NAPro. Chinese variables, comment, descriptions can be used in programs. Working windows, menus, tabs, online help and user manuals are also in Chinese.

### Tree structure for project management

Under the concepts of project management, NAPro has a project browser with a tree structure, displaying multi-document of programs in a visualized mode, which makes it convenient to programming development and maintenance.

### Supporting five programming languages specified in IEC61131-3

NAPro supports all five programming languages specified in IEC61131-3. Different languages could be used within a project and could be called by each other. These five languages include:

LD: Ladder Diagram

ST: Structured text

IL: Instruction List

FBD: Function Block Diagram

SFC: Sequential Function Chart

### **An original Sequential Control Chart (SCC) Programming Language**

As most of control operations in control area are sequential controls, NAPro creates a Sequential Control Chart, which is a simple graphic process description and easy to be accepted by users due to its visualization and convenience.

### **Rich operation control functions**

NAPro not only embeds many standard modules, standard operators and functions, but also provides many practical modules such as pulse digital output, serial communication, network communication, and etc..

### **Online real-time monitoring function**

When online, NAPro could monitor all test points and variables, view SOE events and warning messages, and watch the program execution.

### **Perfect online editing function**

When online, parameters of Ladder Diagram function can be modified directly, and the modified results can be directly transferred to running PLC on the base of ensuring program continuity. In this way, the modifications could get into effect within the same scan cycle. Module delete or movement can also be carried out but require download before real execution.

### **Powerful online debugging function**

When online, programs can be automatically executed, monitor the execution and debug. Breakpoint can be set and single step can be taken. One can stop the execution or restart it at any time. It is very convenient to debug the program.

### **Perfect simulation function**

A PLC simulator is integrated in NAPro, which could precisely reproduce the activity of a target program. This process of programming and debugging can be done without the hardware so as to reduce the length of program development cycle.

### **Friendly software design interface**

NAPro makes the best use of the advantages of Windows graphic and context interface. It improves greatly user friendly experience by optimizing the use of display area, direct visit to tools and information, and bilingual comments, etc..

### **Effective diagnostic tool**

NAPro has an overall function of diagnosing application programs. The compiler window can display clearly all the system and application faults. In this window, modifications can be easily made by simply clicking the mouse and entering the editor where the programs go wrong.

For more detailed information about NAPro programmable software, please refer to “NAPro programmable software manual for NA series PLC”.

## 2 CPU Modules

### Synopsis

The CPU module is the core part of NA300 series PLC; it constructs a complete hardware system of PLC by connecting the expansion bus and expansion modules. The CPU module is responsible for self-diagnosis, data acquisition, control of implementation, external communications, and external output functions, etc.

The CPU Module is also called the system control center. Users download the completed program into the CPU module, then CPU module is activated and run the user program in a loop manner, and in each loop cycle it need to read in the process information, do logical calculation, and output the result of the operations. At the same time, it also need to handle the communications, high-speed counting, event interruption processes, and etc., periodically or according to the time set by the user.

### Content

CPU modules will be described in this chapter

Section	Content
2.1	Basic CPU, 2×RS485 (MODBUS) ,2×NIC(MODBUS/TCP),Program space 8M

Table1. Maximum points of CPU internal register

Register \ CPU type	CPU301-0101
I	1024
Q	1024
IW	256
QW	256
M	8192
MW	8192
N	2048
NW	2048
S	2048

SW	2048
T	512
C	512
V	32768

CPU has its own maximum allowed number of registers. When writing the programs, please check this information carefully, otherwise the compiler will report errors because of use of registers is beyond limit.

## 2.1 Basic CPU 301-0101

### Order Number

CPU Notes	Order No.
Basic CPU, 2×RS485(MODBUS), 2×NIC(MODBUS/TCP), program space 8M	300CPU3010101

### Features:

1. The advantage of high- speed processing and high reliability;
2. Consisting of 2 RS485-ports, supporting MODBUS slave protocol, and communicating with other equipment by terminals;
3. Support floating-point arithmetic;
4. Comes with real-time clock. Recording current time and the process of time control;
5. With watchdog function, it can self-reset and reboot when there is fault;
6. Hot-plugging is supported;
7. Power failure safeguard.
8. Comes with two Ethernet interfaces, with 8M program space, directly access the bit machine system;

### Outlook of CPU Module:

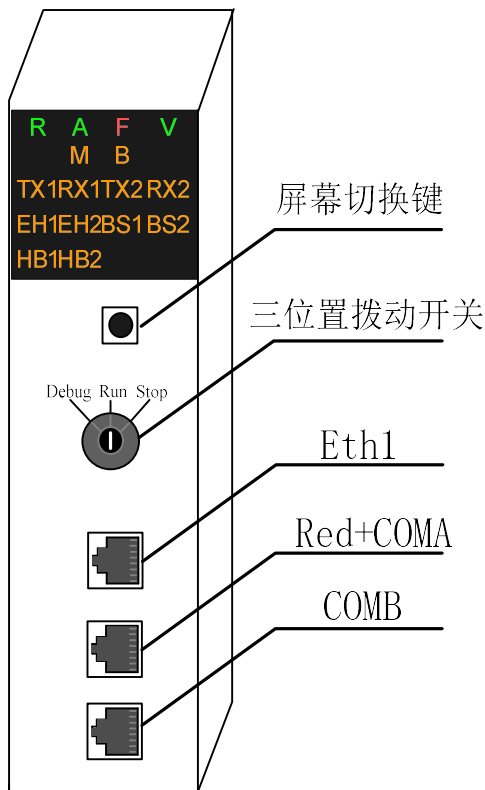

**NA300 CPU301-0101 Module**

**LED Indicator description:**

The LED indicators of CPU modules are located in the upper front panel. As shown below, the status information of CPU is shown by 4 indicator LEDs and OLED. The 4 LEDs are the power indicator (P), the operation indicator (R), the communication status indicator (A) and the fault indicator (F). The OLED mainly indicates the status of RS485 communication, the status of backplane bus and the IP address of Ethernet. When the CPU is on the stage of running, switch the screen through the OLED button, the screen contains two pages in total. As shown below.

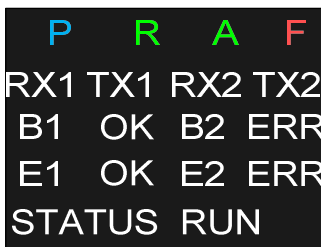

**Show the first page of screen**

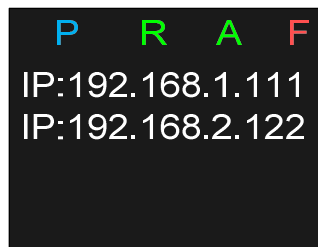

**Show the second page of screen**

**Indicator LEDs**

LED	Color	State	Meaning
p	Blue	Constant lighting / off	Supply power for the module/No power
A	Green	Constant lighting / off	HIN work normally/ no communication or work abnormally
F	Red	Light / off	Fault (Contain no network cable、the fault of internal bus) / Running normal
R	Green	Flicker	Run normally
TX1	Green	Flicker / off	Serial port 1 is sending data/No Data is sending
RX1	Green	Flicker / off	Serial port 1 is receiving data/No Data is received
TX2	Green	Flicker / off	Serial port 2 is sending data/No Data is Sending
RX2	Green	Flicker / off	Serial port 2 is receiving data/No Data is received

**The definition of OLED screen:**

- RX1: The indicator LED is lighting constantly when Serial port1 receives data,and the indicator light is off when there is no data.
- TX1: The indicator LED is lighting constantly when Serial port1 sends data,and the indicator light is off when the Serial port1 sends no data.
- RX2: The indicator LED is lighting constantly when Serial port2 receives data,and the indicator light is off when there is no data.
- TX2: When indicator LED is lighting constantly when Serial port2 sends data,and the indicator light is off when the Serial port1 sends no data.
- B1 OK(ERR): Backplane Bus 1 is normal or fault, this bus is mainly used with NA300 series IO expansion module.
- B2 OK(ERR): Backplane Bus 2 is normal or fault, this bus is mainly used with NA300 series IO expansion module.
- E1 OK (ERR) :Ethernet 1 is normal or error.
- E2 OK (ERR) :Ethernet 2 is normal or error.
- STATUS RUN: Represent the current state of CPU is run.

- IP:192.168.1.111 : Represent the current IP address of Ethernet 1.
- IP:192.168.1.111 : Represent the current IP address of Ethernet 2.

When the state of CPU is debug, OLED screen has 1page. As shown is below.

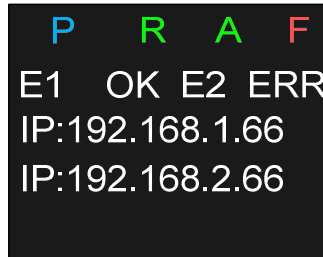

E1 OK (ERR) : Ethernet 1 is normal or fault.

E2 OK (ERR) : Ethernet 2 is normal or fault.

IP:192.168.1.66: Represent the state of CPU is DEBUG and the IP address is 192.168.1.66.

IP:192.168.2.66: Represent the state of CPU is DEBUG and the IP address is 192.168.2.66

## Hardware Setting and External Interface

### 1. OLED Switch

There is OLED button to set the OLED screen lit or OLED screen flip.

#### Light OLED screen

In order to improve the life of screen, the OLED screen will turn off automatically after the OLED screen is lit for 5 minutes. Click the OLED button to turn on the screen to view the screen information.

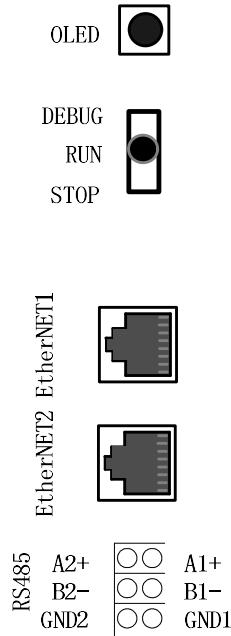

### CPU external interface diagram

#### OLED screen flip

The CPU module OLED screen can display multiple pages, long press the OLED button 2s to switch to the next page to view the next page information.

#### 2. DIP Switch

There is a 3-position switch in the CPU module, which is used to setting the state of the module. The switch is in run position when the module is running normal.

- Stop: When turning the switch to “Stop” position, the CPU module is in a stopped state. The software stop scanning the program.
- Debug: When turning the switch to “Debug” position, the CPU module is in a debug state, and the Watchdog of the module will be disabled. Debug the user program at this point.
- RUN: When turning the switch to “Run” position, the CPU module is in a normal state. Watchdog will be activated, when the CPU module appears to be running chaos or crash due to some kinds of interference or hardware failure. The module could be reset automatically.

#### 3. RS485 interface

The CPU module has two basic MODBUS RS485 ports which communicate with other external equipments.

The Definition of Serial port is as follows:

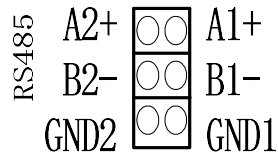

#### 4. Ethernet interface

CPU module of NA300 CPU301-0101 has two Ethernet interfaces which are used for debugging the downloaded user programs. The Ethernet interface is defined as follows:

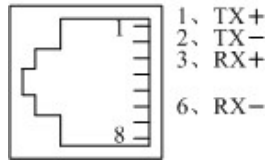

#### Technical Specification

CPU type		CPU301-0101
Order NO.		300CPU3010101
CPU basic frequency		400MHz
CPU Processing Capacity	Bit Instruction Speed	0.05us
	Word Instruction Speed	0.1us
	Integer Arithmetic Speed	0.1us
	Floating Point Arithmetic	1us
Memory Property	Program	8M
	Data	8M
Power Voltage	Upper Limit	5.25V
	Rating	5.0V
	Lower Limit	4.75V
Current Consumption	Upper Limit	0.6A
	Rating	0.5A
	Typical Power Consumption	2.5W

Support Redundant CPU		NO
Ethernet Interface		2
RS485 Serial Ports	Number	2
	Support baud rate	2.4-38.4kbps
Communicate Ability	Modbus	YES
Program Language	LD	YES
	ST	YES
	IL	YES
	FBD	YES
	SFC	YES
	SCC	YES
Weight (g)		160
Installing Size (Length×Height×Depth) (mm)		32×110×97

## 3 Power supply module

### Synopsis

In order to adapt to different of application situations, NA300 PLC offer several kinds of power supply modules. Power supply modules include LED window, switch, connection terminal etc. All power supply modules can supply isolated 5VDC power to the backplane bus used by other modules.

### Content

In this chapter, the following will be described:

Section	Content
3.1	Power supply module PWM301-24V DC input
3.2	Power supply module N+1 Redundant Power PWM301-0403

### 3.1 Power supply module PWM301-24VDC

#### Order Number

Power supply module Notes	Order No.
24V DC Input, rated current: 8A Power: 40W	300PWM3010401

#### Features:

1. Input: 24V DC.
2. Output: 5V DC.
3. Input under-voltage protection, over-current, and over-voltage protection.
4. Reliable isolation.
5. Can be controlled by the switch.

#### Wiring Diagram

External power of power supply module is connected by a 3-position ot-plugging connection terminal. The pin definition is shown in the figure below:

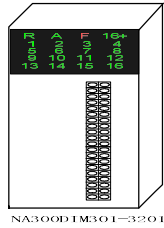

**Specification of the switch**

Position of the switch	Definition
ON	Power supply module output rated voltage
OFF	Power supply module output 0V

**Module outlook**

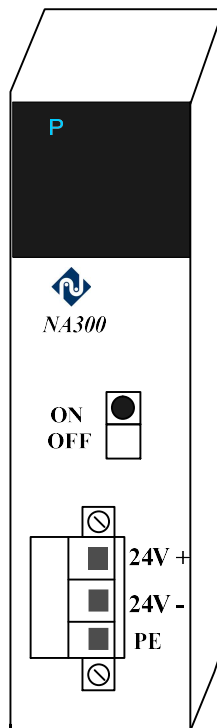

**NA300-24V Power supply module**

**Specification of LED indicator**

LED	Color	Definition
P	Blue	The power module outputs the rated voltage

**Technical Specification:**

Module Type	PWM301-0401
Order NO.	300PWM3010401
Voltage Input	24VDC
Voltage Output	+5V
Rated Current	8A
Connection Mode	Terminal
Status Indicator	Support
Weight (g)	200
Installing Size (Length×Height×Depth) (mm)	32×110×97

**3.2 N+1 Redundant Power supply module:  
PWM301-0403**

**Order Number**

Power supply module Notes	Order No.
24V DC Input, rated current: 8A Power: 40W N+1 Redundant Power,with power failure diagnosis	300PWM3010403

**Features:**

1. Input:. 24VDC.
2. Output:. 5VDC.
3. Input under-voltage protection, over-current, and over-voltage protection.
4. Reliable isolation.
5. Can be controlled by the switch.
6. Intelligent module with self-diagnosis function can be reset and reboot automatically when fault.
7. Hot plugging support.
8. Power down alarm.
9. N+1 Mode Redundant Power Supply Module.

### Principle of The Redundancy

The N+1 power rail controller, in conjunction with an external N-channel MOSFET, emulates the function of a low forward voltage diode.

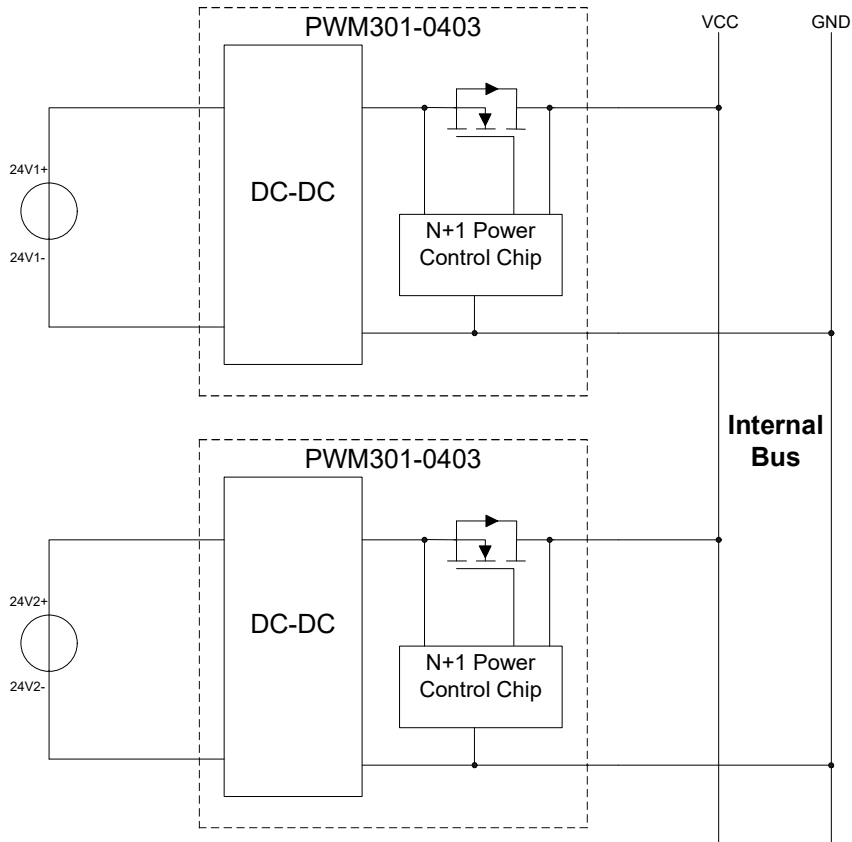

### PWM301-0403 Power Supply Example

The N+1 power supply configuration shown above is used where multiple power supplies are paralleled for either higher capacity, redundancy or both. If it takes N supplies to power the load, adding an extra, identical unit in parallel permits the load to continue operation in the event that any one of the N supplies fails. The supplies are ORed together, rather than directly connected to the bus, to isolate the converter output from the bus when it is plugged-in or fails short. The power rail controller with an external MOSFET emulates the function of the ORing diode.

### Wiring Diagram

External power of power supply module is connected by a 3-position hot-plugging connection terminal. The pin definition is shown in the figure below:

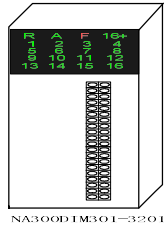

**Specification of the switch**

Position of the key switch	Definition
ON	Power supply module output rated voltage
OFF	Power supply module output 0V

**Module outlook**

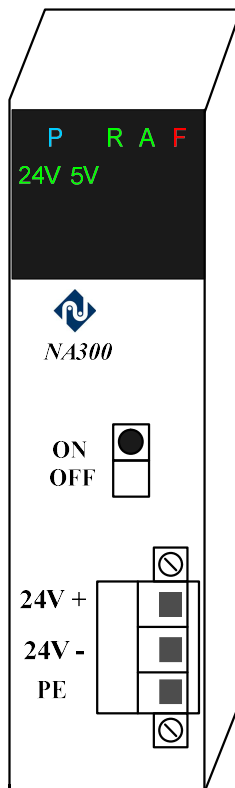

**Power supply module PWM301-0403**

**Definition of LED**

LED	Color	State	Meaning
-----	-------	-------	---------

P	Blue	Light / off	Bus Power on/Bus Power off
R	Green	Flicker/Constant Lighting	Run normally/ Run but parameters are not loaded
A	Green	Constant Lighting / off	HIN work normally/ abnormally
F	Red	Light / off	Fault/ Running normal
24V	Green	Light / off	24V voltage is within tolerance/24V voltage is not within tolerance
5V	Green	Light / off	5V voltage is within tolerance/5V voltage is not within tolerance

**Technical Specification:**

Module type	PWM301-0403
Order NO.	300PWM4010403
Voltage Input	24VDC
Voltage Output	+ 5V
Rated Current	8A
Connection Mode	Terminal
State Denotation	Support
Weight (g)	200
Installing Size (Length×Height×Depth) (mm)	32×110×97

## 4 Digital I/O Module

### Synopsis

In this chapter, all types of digital I/O modules are introduced, in which the I/O return circuit can not only be connected to the switch sensor of push button or limit switch, but also be connected to the digital switch actuator such as indicator lamp of motor starter or alarm annunciator. The status of certain bits on the data sheet of PLC will directly control output, and the input will directly control corresponding bits on the data sheet of PLC.

This chapter will introduce the following subjects:

1. Introduction of available modules
2. The most important characteristics of modules
3. Appearance and Wiring schematic of digital modules

### Content

This chapter will introduce the following I/O modules:

Section	Content
4.1	Digital input module DIM301-1601
4.2	Digital input module DIM301-3201
4.3	SOE module IIM301-1601
4.4	SOE module IIM301-3201
4.5	Digital output module DOM301-1601
4.6	Digital output module DOM301-3201

NA300 series PLC provide many kinds of digital expand modules for users, including normal digital input module NA300 DIM301, sequence of events input module, NA300 IIM301 and digital output module. Please see table 4.1 for more information.

Table 4.1 List of NA300 I/O modules

Type	Name	Specification
DIM301-1601	16 channel Digital input module	DI16×DC24V(Sink or Source)

DIM301-3201	32 channel Digital input module	DI32×DC24V (Sink or Source)
IIM301-1601	16 channel SOE module	IIM16×DC24V
IIM301-3201	32 channel SOE module	IIM32×DC24V
DOM301-1601	16 channel Digital output module	DO16×DC24V×Transistor
DOM301-3201	32 channel Digital output module	DO32×DC24V×Transistor

## 4.1 Digital input module DIM301-1601:DI16×DC24V

### Order Number

300DIM3011601

### Features:

1. 16 points input with 8 points (also called “channels”) per group using a common terminal, sink input type.
2. Rated input voltage 24VDC.
3. Applicable to switch and 2/3/4 proximity switch.
4. Every DI test point could be set of a 10~100ms filtering time by software.
5. Intelligent module with self-diagnosis function can be reset and reboot automatically when fault.
6. No need for hardware setting. The CPU Module can load parameters on it automatically after start up.
7. Every channel has an independent electricity isolation, which ensures that whole module can run safely even when one certain signal channel is disturbed by heavy current.
8. Hot plugging support.

### Diagram of Interface

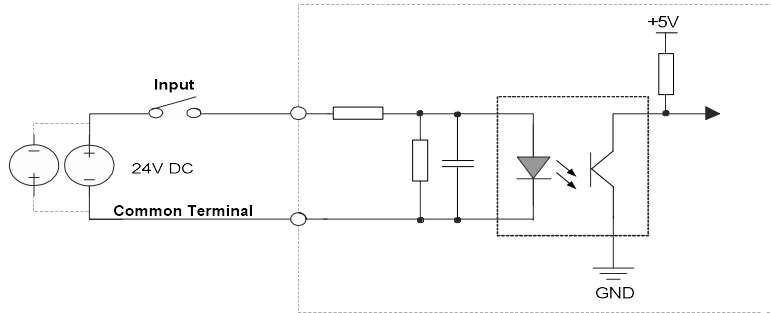

**Diagram of DIM301-1601 Single Channel Interface Circuit**

**Terminal wiring diagram**

DIM301-1601 Digital input module connect with external devices by terminal blocks in front of the module. Correspondence of each channel is described in the following figure.

And please pay attention to the following:

- DIM301-1601 digital input module requires a separate 24VDC field power supply.
- Every 8 channels form a group and share a common terminal. There are all two common terminals. 16 channels can be divided into 2 groups, each of which requires a separate 24VDC filed power supply.
- NO. "17" pin is the input common terminal of field power supply, as the common terminal of point 1 to 8; NO."1,3,5,7,9,11,13,15" pin are the digital input for point 1 to 8 in turn; NO. "35" pin is the input common terminal of field power supply, as the common terminal of point 9 to 16; NO."19,21,23,25,27,29,31,33" pin are the digital input for point 9 to 16 in turn.
- Please don't connect more than 2 cables to the same pin of the terminal. It is better to realize multipoint cable access by busbar or transfer terminal.

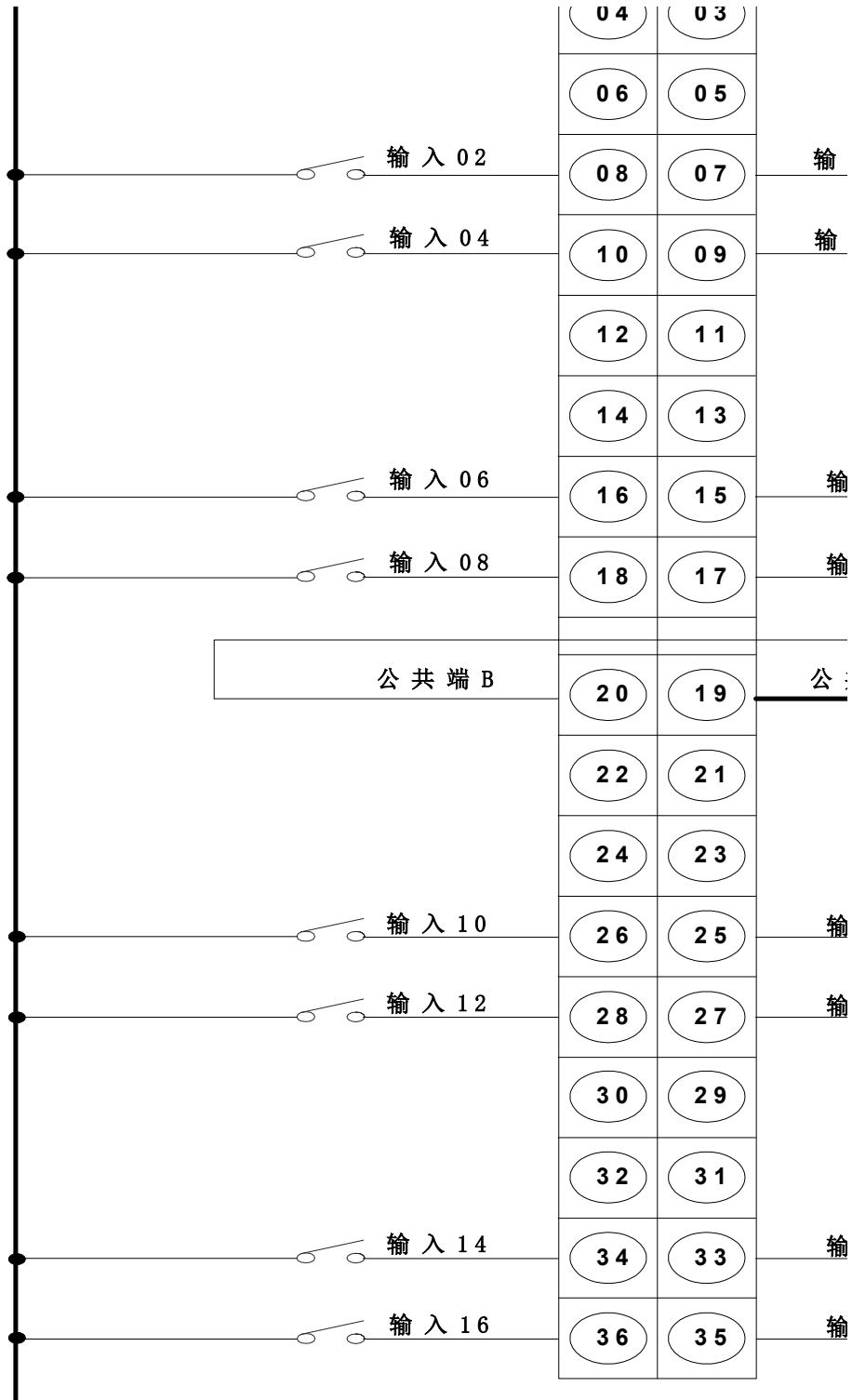

DIM301-1601 Terminal wiring diagram

Indicator LED description:

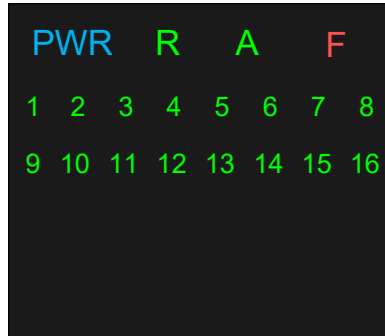

**Indicator LEDs**

**Description of indicator LEDs:**

LED	Color	State	Meaning
P	Blue	Constant Lighting/ off	Power on/off
R	Green	Flicker/Constant Lighting	Run normally/run but parameters are not loaded
A	Green	Constant Lighting / off	HIN work normally/ abnormally
F	Red	Light / off	Fault/ Running normal
Indicator Light 1-16	Green	Light / off	Current state of input is 1/ Current state of input is 0

**The working state corresponding to the indicator LED is as follows:**

- P: Power Indicator LED. The LED is on when the module is powered on . The LED will go off when the module is powered off.
- R: Run Indicator LED. When the module is running normal, the green LED flickers. If the green LED is always on, that means program has been running but parameter is unloaded.
- A: Communication Indicator LED. When CPU module can communicate normally with other modules through HIN, the LED is on.
- F: Fault Indicator LED. The LED is on when the module has fault. The LED will go off when everything is normal.
- 1-16 Channel Indicator LED: Every green light shows state of one input signal. For digital input module, when the light is on, it means the current state of the

input signal is 1, otherwise it is 0.

### Technical Specification

Points	16
Input Type	Sink or source
Module Load	200mA/5V
Power Consumption	1W
Self Diagnosis Function	YES
Input Filter	10~100ms manually
Insulation Test	500VDC
Nominal Input Voltage	24VDC
"1"Signal Voltage	14~30V
"0"Signal Voltage	-30~5V
Response Time (ON)	<=0.5ms
Response Time (OFF)	<=0.5ms
Installing Size (width×height×depth mm)	32×110×97
Weight	140g
Operating Temperature	-10~60□
Status Indicator	Green indicator LED for each digital input point

## 4.2 Digital input module DIM301-3201: DI32×DC24V

### Order Number

300DIM3013201

### Features:

1. 32 points input with 16 points (also called “channels”) per group sharing a common terminal, source or sink input type.
2. Rated input voltage 24VDC.
3. Applicable to switch and 2/3/4 proximity switch.
4. Every DI point could be set 10~100ms filtering time by software.
5. Intelligent module with self-diagnosis function can be reset and reboot automatically when fault.
6. No need for hardware setting. The CPU Module can load parameters on it automatically after start up.
7. Every channel has an independent electricity isolation, which ensures that whole module can run safely even when a certain signal channel is disturbed by heavy current.
8. Hot plugging support.

### Diagram of Interface

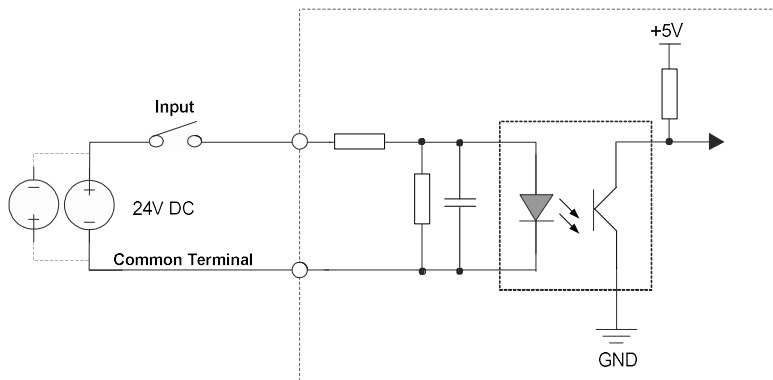

**Diagram of DIM301-3201 Single Channel Interface Circuit**

### Terminal wiring diagram

DIM301-3201 Digital input module connect with external devices by terminal blocks in front of the module. Correspondence of each channel is described in the following figure. And please pay attention to the following:

- DIM301-3201 digital input module requires a separate 24VDC field power supply.
- Every 16 channels form a group and share a common terminal. There are all two

common terminals. 32 channels can be divided into 2 groups, each of which requires a separate 24VDC field power supply.

- NO. "17,35" pin is the input common terminal of field power supply, as the common terminal of point 1 to 16; NO."1,3,5,7,9,11,13,15,19,21,23,25,27,29,31,33,35" pin are the digital input for point 1 to 8 in turn; NO. "18,36" pin is the input common terminal of field power supply, as the common terminal of point 17 to 32;
- NO."2,4,6,8,10,12,14,16,20,22,24,26,28,30,32,34" pin are the digital input for point 17 to 32 in turn.
- Please don't connect more than 2 cables to the same pin of the terminal. It is better to realize multipoint cable access by busbar or transfer terminal.

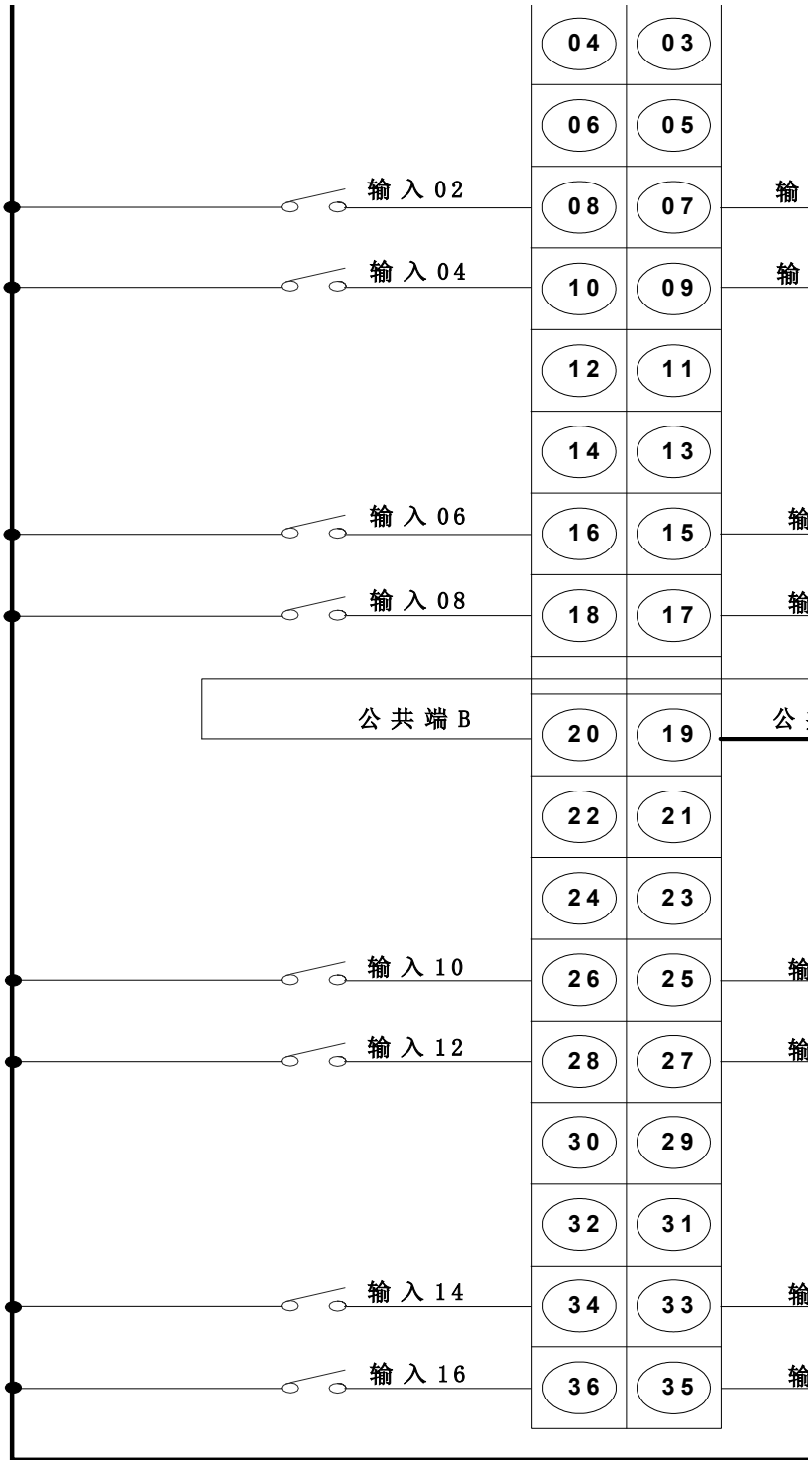

DIM301-3201 Terminal wiring diagram

Indicator LED description:



**Indicator LEDS**

**Descriptions of indicator LEDs:**

LED	Color	State	Meaning
P	Blue	Constant Lighting/ off	Power on/off
R	Green	Flicker/Constant Lighting	Run normally/run but parameters are not loaded
A	Green	Constant Lighting / off	HIN work normally/ abnormally
F	Red	Light / off	Fault/ Running normal
Indicator Light 1-32	Green	Light / off	Current state of input is 1/ Current state of input is 0

**The working state corresponding to the indicator LED is as follows:**

- P: Power Indicator LED. The LED is on when the module is powered on . The LED will go off when the module is powered off.
- R: Run Indicator LED. When the module is running normal, the green LED flickers. If the green LED is always on, that means program has been running but parameter is unloaded.
- A: Communication Indicator LED. When CPU module can communicate normally with other modules through HIN, the LED is on.
- F: Fault Indicator LED. The LED is on when the module has fault. The LED will go off when everything is normal.
- 1-32 Channel Indicator LED: Every green light shows state of one input signal. For digital input module, when the light is on, it means the current state of the input signal is 1, otherwise it is 0.

**Technical Specification**

Points	32
Input Type	Sink or source
Module Load	320mA/5V
Power Consumption	1.6W
Self Diagnosis Function	YES
Input Filter	10~100ms manually
Insulation Test	500VDC
Nominal Input Voltage	24VDC
“1”Signal Voltage	14~30V
“0”Signal Voltage	-30~5V
Response Time (ON)	<=0.5ms
Response Time (OFF)	<=0.5ms
Installing Size (width×height×depth mm)	32×110×97
Weight	160g
Operating Temperature	-10~60□
Status Indicator	Green indicator LED for each digital input point

**4.3 Sequence of Event (SOE) Module IIM301-1601:**

**IIM16×DC24V**

**Order Number**

300IIM3011601

**Features:**

1. 16 points input with 1 group, 8 points(also called “channels”) per group, using a common terminal, sink or source input type.
2. Rated input voltage 24VDC.
3. Applicable to switch and 2/3/4 proximity switch.

4. Every DI point could be set 10~100ms filtering time by software.
5. Intelligent module with self-diagnosis function can be reset and reboot automatically when fault.
6. No need for hardware setting. The CPU Module can load parameters on it automatically after start up.
7. Every channel has an independent electricity isolation, which ensures that whole module can run safely even when a certain signal channel is disturbed by heavy current.
8. Every channel in IIM301-1601 module has SOE function. When shift takes place in input signal, the shift information and action time can be transmitted automatically to CPU module with a resolution of 1ms.
9. Hot plugging support.

### Diagram of Interface

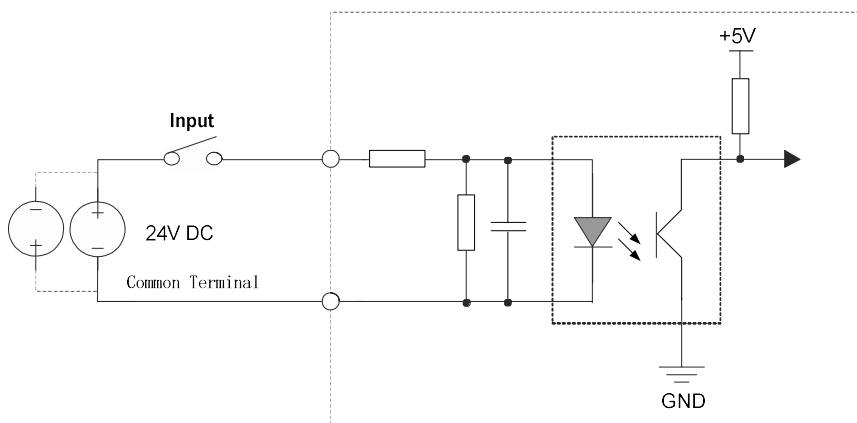

**Diagram of IIM301-1601 Single Channel Interface Circuit**

### Terminal wiring diagram

IIM301-1601 sequence of event module connects with external devices by terminal blocks in front of the module. Correspondence of each channel is described in the following figure. And please pay attention to the following:

- IIM301-1601 sequence of event module requires a separate 24VDC field power supply.

- Every 8 channels form a group and share a common terminal. There are all two common terminals. 16 channels can be divided into 2 groups, each of which requires a separate 24VDC field power supply.
- NO. "17" pin is the input common terminal of field power supply, as the common terminal of point 1 to 8; NO."1,3,5,7,9,11,13,15" pin are the digital input for point 1 to 8 in turn; NO. "35" pin is the input common terminal of field power supply, as the common terminal of point 9 to 16; NO."19,21,23,25,27,29,31,33" pin are the digital input for point 9 to 16 in turn.
- Please don't connect more than 2 cables to the same pin of the terminal. It is better to realize multipoint cable access by busbar or transfer terminal.

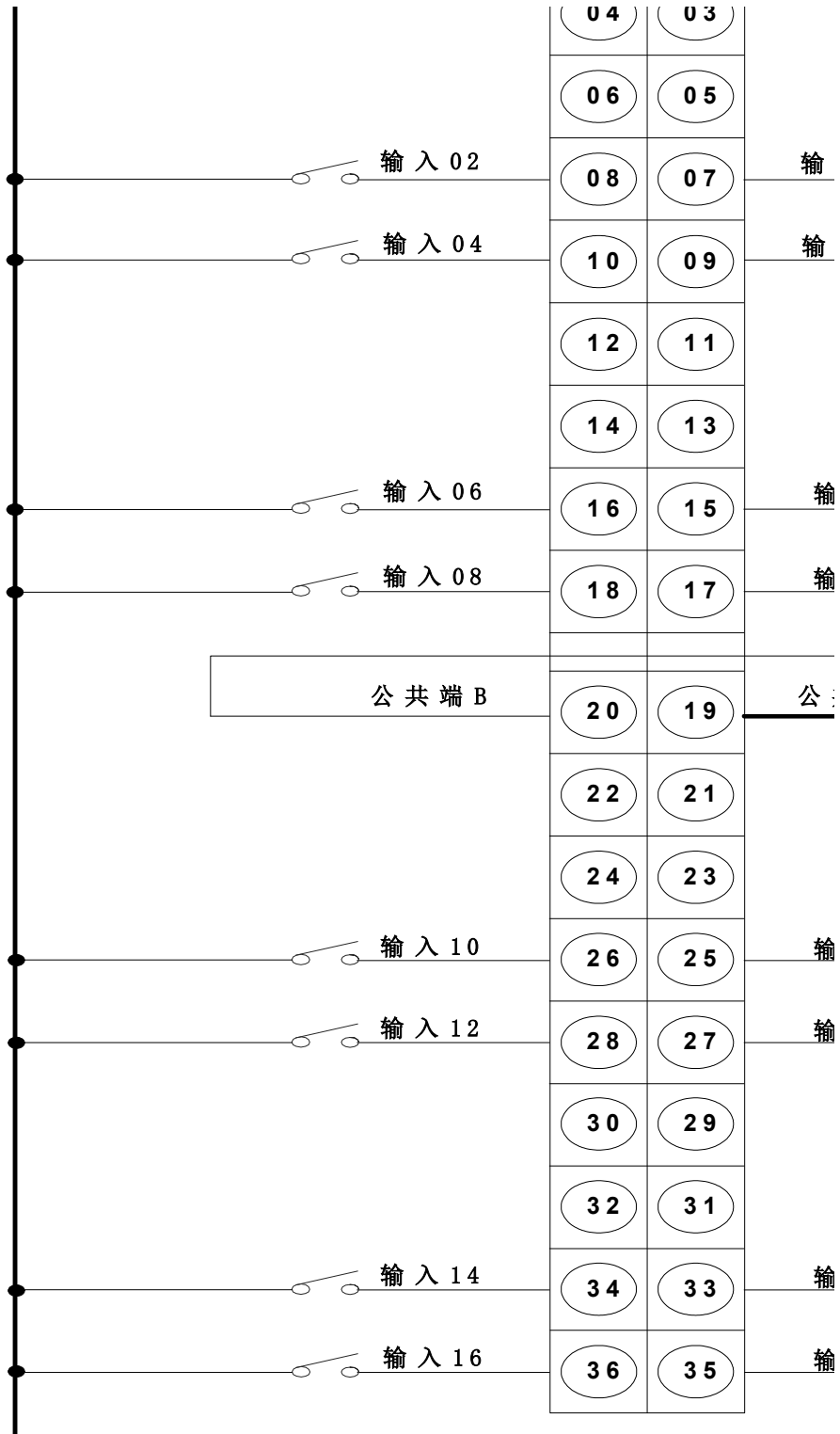

IIM301-1601 Terminal wiring diagram

Indicator LED description:

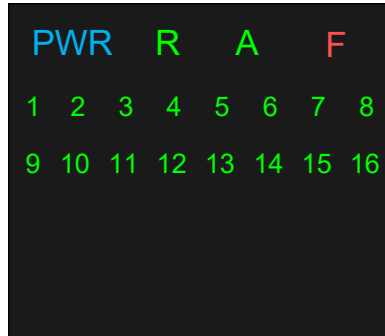

**Indicator LEDS**

**Description of indicator LEDs:**

LED	Color	State	Meaning
P	Blue	Constant Lighting/ off	Power on/off
R	Green	Flicker/Constant Lighting	Run normally/run but parameters are not loaded
A	Green	Constant Lighting / off	HIN work normally/ abnormally
F	Red	Light / off	Fault/ Running normal
Indicator Light 1-16	Green	Light / off	Current state of input is 1/ Current state of input is 0

**The working state corresponding to the indicator LED is as follows:**

- P: Power Indicator LED. The LED is on when the module is powered on . The LED will go off when the module is powered off.
- R: Run Indicator LED. When the module is running normal, the green LED flickers. If the green LED is always on, that means program has been running but parameter is unloaded.
- A: Communication Indicator LED. When CPU module can communicate normally with other modules through HIN, the LED is on.
- F: Fault Indicator LED. The LED is on when the module has fault. The LED will go off when everything is normal.
- 1-16 Channel Indicator LED: Every green light shows state of one input signal. For digital input module, when the light is on, it means the current state of the

input signal is 1, otherwise it is 0.

### Technical Specification

Points	16
Input Type	Sink or source
Module Load	200mA/5V
Power Consumption	1W
Self Diagnosis Function	YES
Input Filter	10~100ms manually
Insulation Test	500VDC
Nominal Input Voltage	24VDC
“1”Signal Voltage	14~30V
“0”Signal Voltage	-30~5V
Response Time (ON)	<=0.5ms
Response Time (OFF)	<=0.5ms
Installing Size (width×height×depth mm)	32×110×97
Weight	140g
Operating Temperature	-10~60□
Status Indicator	Green indicator LED for each digital input point

## 4.4 Sequence of Event (SOE) Module IIM301-3201:

### IIM32×DC24V

#### Order Number

300IIM3013201

#### Features:

1. 32 points input with 1 group, 16 points(also called “channels”) per group, using a common terminal, sink or source input type.
2. Rated input voltage 24VDC.

3. Applicable to switch and 2/3/4 proximity switch.
4. Every DI point could be set 10~100ms filtering time by software.
5. Intelligent module with self-diagnosis function can be reset and reboot automatically when fault.
6. No need for hardware setting. The CPU Module can load parameters on it automatically after start up.
7. Every channel has an independent electricity isolation, which ensures that whole module can run safely even when a certain signal channel is disturbed by heavy current.
8. Every channel in IIM301-1601 module has SOE function. When shift takes place in input signal, the shift information and action time can be transmitted automatically to CPU module with a resolution of 1ms.
9. Hot plugging support.

### Diagram of Interface

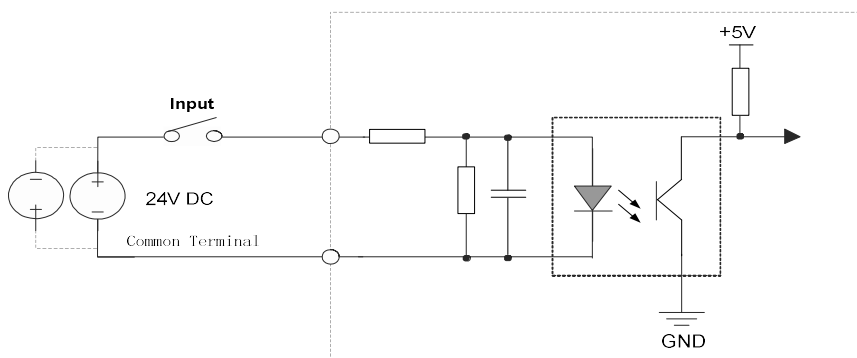

**Diagram of IIM301-3201 Single Channel Interface Circuit**

### Terminal wiring diagram

IIM301-3201 sequence of event module connects with external devices by terminal blocks in front of the module. Correspondence of each channel is described in the following figure. And please pay attention to the following:

- IIM301-3201 sequence of event module requires a separate 24VDC field power supply.
- Every 16 channels form a group and share a common terminal. There are all two

common terminals. 32 channels can be divided into 2 groups, each of which requires a separate 24VDC field power supply.

- NO. "17,35" pin is the input common terminal of field power supply, as the common terminal of point 1 to 16; NO."1,3,5,7,9,11,13,15,19,21,23,25,27,29,31,33,35" pin are the digital input for point 1 to 16 in turn; NO. "18,36" pin is the input common terminal of
- Field power supply, as the common terminal of point 17 to 32, NO "2,4,6,8,10,12,14,16,20,22,24,26,28,30,32,34" pin are the digital input for point 17 to 32 in turn.
- Please don't connect more than 2 cables to the same pin of the terminal. It is better to realize multipoint cable access by busbar or transfer terminal.

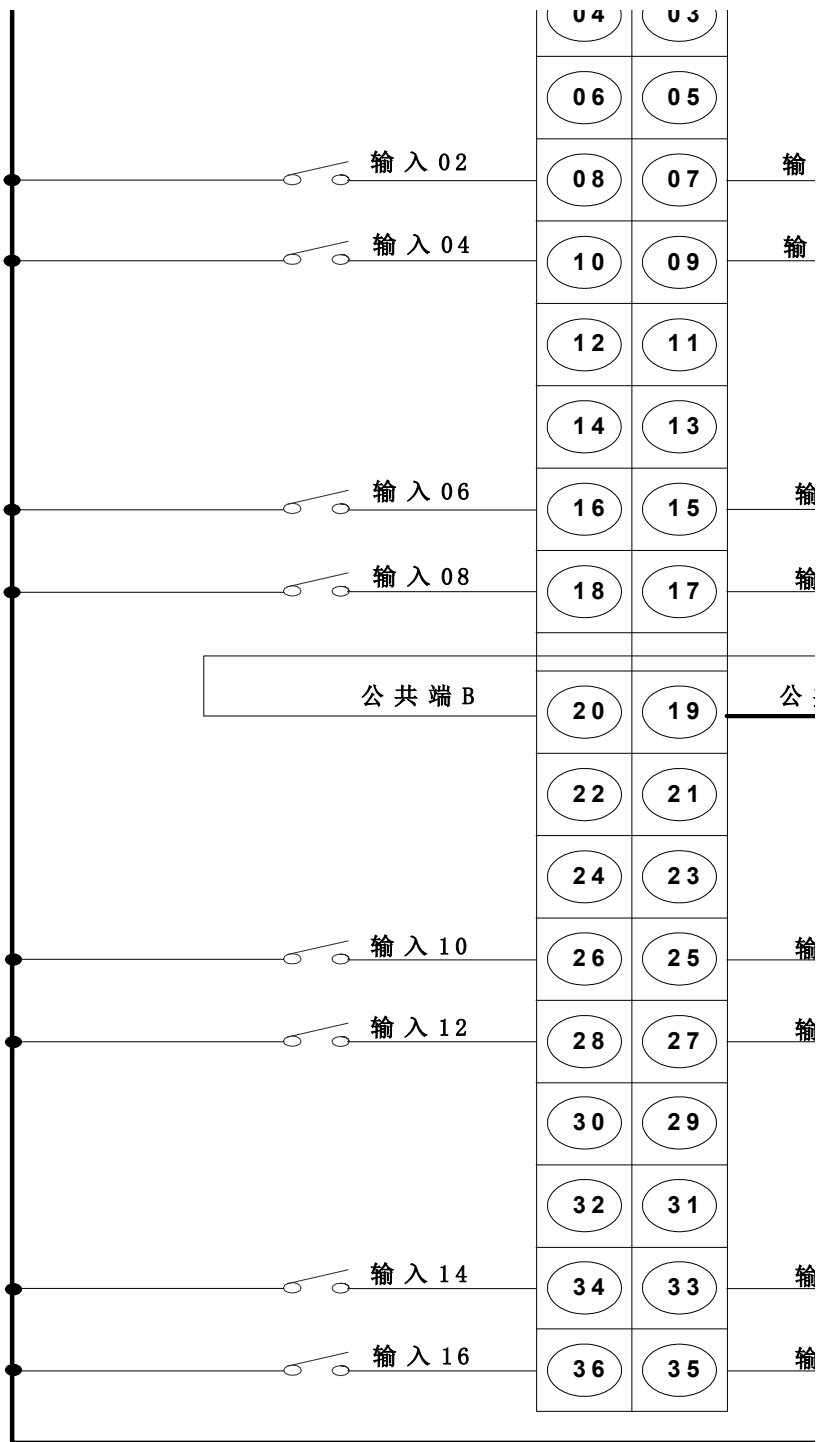

IIM301-3201 Terminal wiring diagram

Indicator LED description:



**Indicator LEDs**

**Description of indicator LEDs:**

LED	Color	State	Meaning
P	Blue	Constant Lighting/ off	Power on/off
R	Green	Flicker/Constant Lighting	Run normally/run but parameters are not loaded
A	Green	Constant Lighting / off	HIN work normally/ abnormally
F	Red	Light / off	Fault/ Running normal
Indicator Light 1-32	Green	Light / off	Current state of input is 1/ Current state of input is 0

**The working state corresponding to the indicator LED is as follows:**

- P: Power Indicator LED. The LED is on when the module is powered on . The LED will go off when the module is powered off.
- R: Run Indicator LED. When the module is running normal, the green LED flickers. If the green LED is always on, that means program has been running but parameter is unloaded.
- A: Communication Indicator LED. When CPU module can communicate normally with other modules through HIN, the LED is on.
- F: Fault Indicator LED. The LED is on when the module has fault. The LED will go off when everything is normal.
- 1-32 Channel Indicator LED: Every green light shows state of one input signal. For digital input module, when the light is on, it means the current state of the input signal is 1, otherwise it is 0.

**Technical Specification**

Points	32
Input Type	Sink or source
Module Load	320mA/5V
Power Consumption	1.6W
Self Diagnosis Function	YES
Input Filter	10~100ms manually
Insulation Test	500VDC
Nominal Input Voltage	24VDC
“1”Signal Voltage	14~30V
“0”Signal Voltage	-30~5V
Response Time (ON)	<=0.5ms
Response Time (OFF)	<=0.5ms
Installing Size (width×height×depth mm)	32×110×97
Weight	160g
Operating Temperature	-10~60□
Status Indicator	Green indicator LED for each digital input point

**4.5 Digital output module DOM301-1601: DO16×DC2  
4V×Transistor**

**Order Number**

300DOM3011601

**Features:**

1. 16 points output with isolation, 16 points(also called “channels”) per group using a common terminal.
2. Rated output type 24VDC transistor, source type of output.
3. Every group of output has a fuse which can protect the module automatically if it is over loaded.

4. Intelligent module with self-diagnosis function can be reset and reboot automatically when fault.
5. No need for hardware setting. The CPU Module can load parameters on it automatically after start up.
6. Hot plugging support.
7. It can be set to “0” or “1” function and to maintain the last state function when fault.

### Diagram of Interface

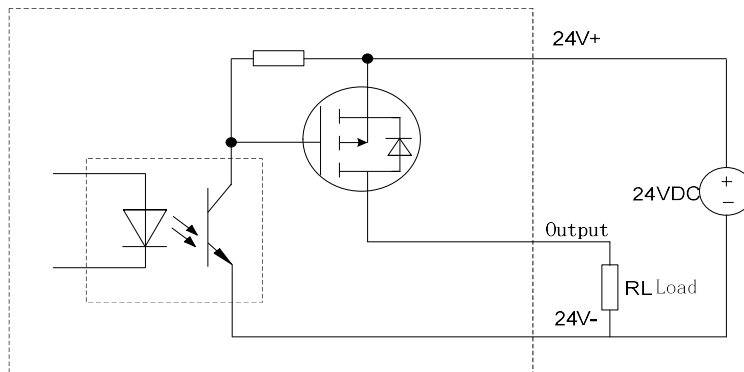
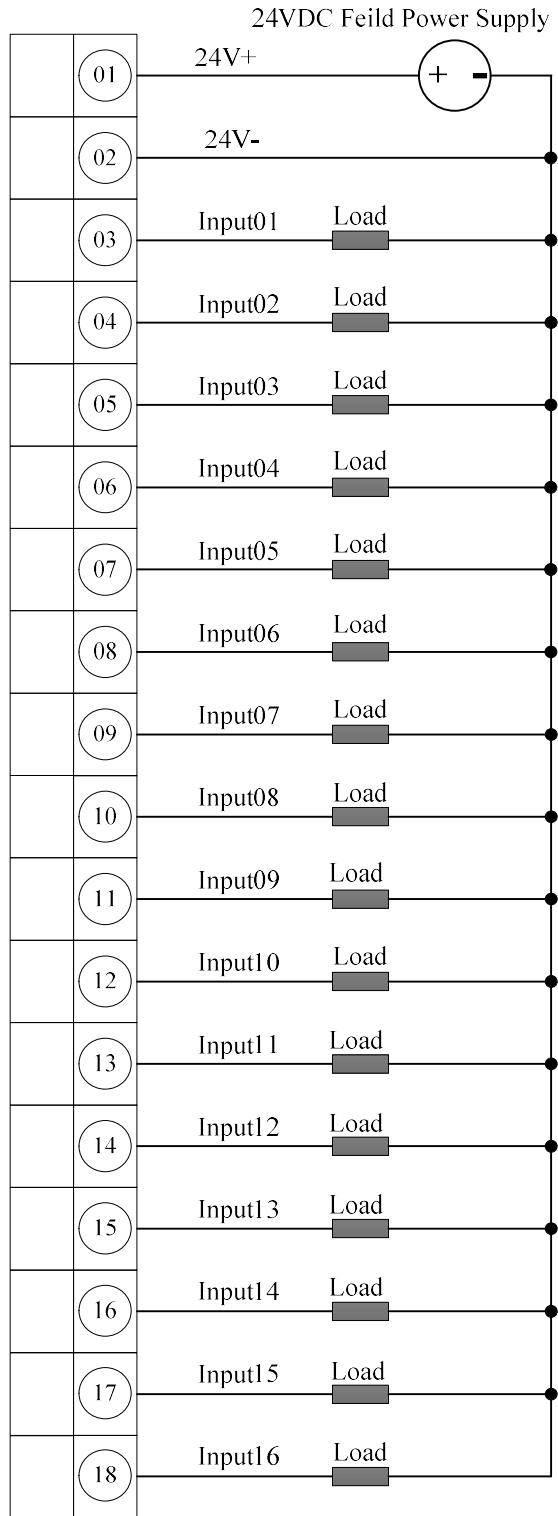

Diagram of DOM301-1601 Single Channel Interface Circuit

### Terminal wiring diagram

DOM301-1601 Digital output module connects with external devices by terminal blocks in front of module. Correspondence of each channel is described in the following drawing. And please pay attention to the following:

- DOM301-1601 digital output module need to use user-supplied power supply 24VDC separately.
- All the 16 points in one group use the same 24VDC supply.
- NO. “1、2” are pins of the terminal should be connected to the field power supply, with NO.1 connecting to positive pole of 24VDC, and NO.2 connecting to negative pole of 24VDC. NO.“3~18” pin is digital output point 1 to digital output point 16 in turn.
- Please don't connect more than 2 cables to the same pin of the terminal, it is better to realize multipoint cable access by busbar or transfer terminal.



**DOM301-1601 Terminal wiring diagram**

**Indicator LED description:**

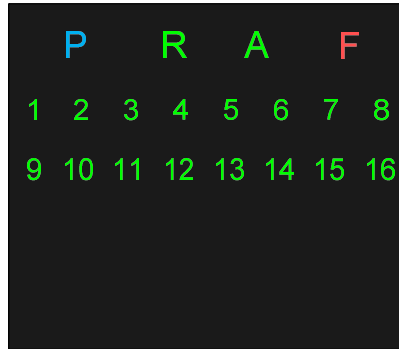

**Indicator LEDs**

**Description of indicator LEDs:**

LED	Color	State	Meaning
P	Blue	Lighting/ off	Power on/off
R	Green	Flicker/Constant Lighting	Run normally/run but parameters are not loaded
A	Green	Lighting / off	HIN work normally/ abnormally
F	Red	Light / off	Fault/ Running normal
Indicator Light 1-16	Green	Light / off	Current state of input is 1/ Current state of input is 0

**The working state corresponding to the indicator LED is as follows:**

- P: Power Indicator LED. The LED is on when the module is powered on . The LED will go off when the module is powered off.
- R: Run Indicator LED. When the module is running normal, the green LED flickers. If the green LED is always on, that means program has been running but parameter is unloaded.
- A: Communication Indicator LED. When CPU module can communicate normally with other modules through HIN, the LED is on.
- F: Fault Indicator LED. The LED is on when the module has fault. The LED will go off when everything is normal.
- 1-16 Channel Indicator LED: Every green light shows state of one input signal. For digital input module, when the light is on, it means the current state of the input signal is 1, otherwise it is 0.

**Technical Specification**

Points		16
Module Load		300mA/5V
Power Consumption		1.5W
Output Voltage		24VDC
Output Type		Transistor, source type
Continuous current per channel(0~40□)		0.5A
Maximum continuous current per channel (0~40□)		0.6A,100ms
Minimum continuous current per channel		5mA
Switching Frequency	Resistive Loading	100Hz
	Inductive Loading	0.5 Hz
Installing Size (width×height×depth mm)		32×110×97
Weight		140g
Operating Temperature		-10~60□
Status Indicator		Green indicator LED for each digital input point
Self Diagnosis Function		Yes
Insulation Test		500VDC
Channel Separation	Adjacent Channel Isolation	Yes
	Isolation Between Channel and Backplane	Yes, optical isolation

**4.6 Digital output module DOM301-3201: DO32×DC2 4V×Transistor**

**Order Number**

300DOM3013201

**Features:**

1. 32 points output with isolation, 16 points(also called “channels”) per group using a common terminal.
2. Rated output type 24VDC transistor, source type of output.
3. Every group of output has a fuse which can protect the module automatically if it is over loaded.
4. Intelligent module with self-diagnosis function can be reset and reboot automatically when fault.
5. No need for hardware setting. The CPU Module can load parameters on it automatically after start up.
6. Hot plugging support.
7. It can be set to “0” or “1” function and to maintain the last state function when fault.

**Diagram of Interface**

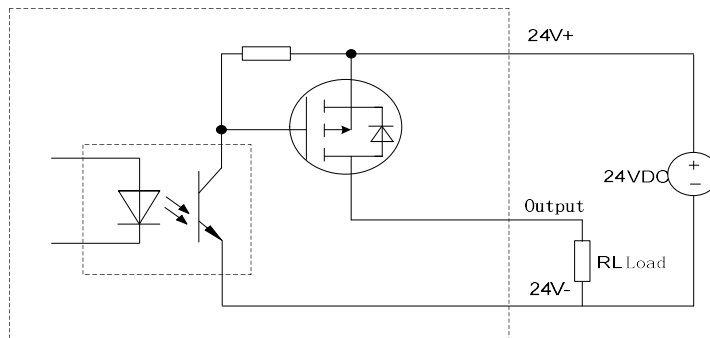

**Diagram of DOM301-3201 Single Channel Interface Circuit**

**Terminal wiring diagram**

DOM301-3201 Digital output module connects with external devices by terminal blocks in front of module. Correspondence of each channel is described in the following drawing. And please pay attention to the following:

- DOM301-3201 digital output module need to use user-supplied power supply 24VDC separately.

- Every 16 channels form a group and share a common terminal. There are all two common terminals. 32 channels can be divided into 2 groups, each of which requires a separate 24VDC field power supply.
- NO. “1、 3” are pins of the terminal should be connected to the field power supply, with NO.1 connecting to positive pole of 24VDC, and NO.3 connecting to negative pole of 24VDC. NO.“5,7,9,11,13,15,17,19,21,23,25,27,29,31,33,35” pin is digital output point 1 to digital output point 16 in turn. NO. “2、 4” are pins of the terminal should be connected to the field power supply, with NO.2 connecting to positive pole of 24VDC, and NO.4 connecting to negative pole of 24VDC.
- NO.“6,8,10,12,14,16,18,20,22,24,26,28,30,32,34,36” pin is digital output point 17 to digital output point 32 in turn.
- Please don't connect more than 2 cables to the same pin of the terminal, it is better to realize multipoint cable access by busbar or transfer terminal.

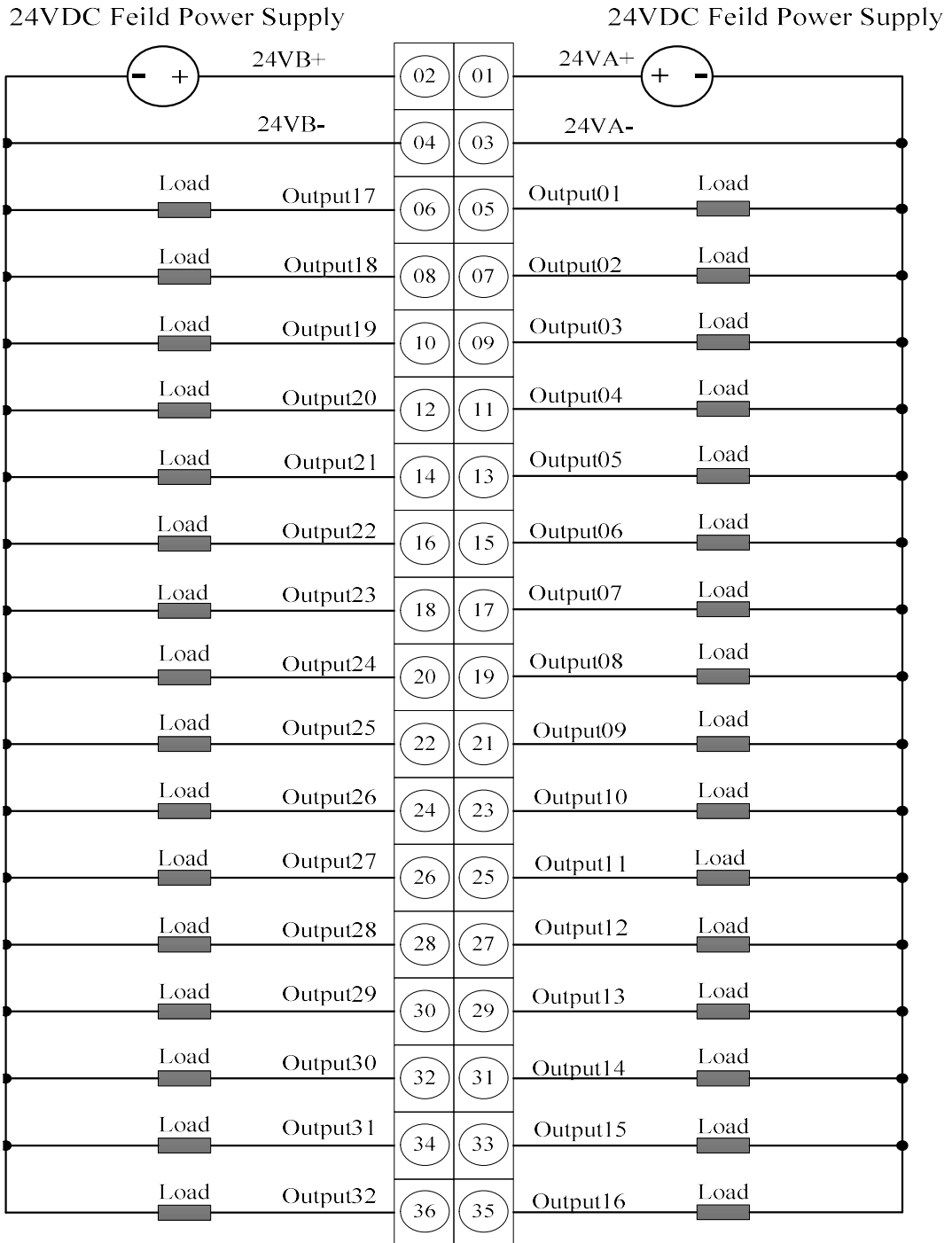

**DOM301-3201 Terminal wiring diagram**

**Indicator LED description:**



**Indicator LEDS**

**Descriptions of indicator LEDs:**

LED	Color	State	Meaning
P	Blue	Lighting/ off	Power on/off
R	Green	Flicker/Constant Lighting	Run normally/run but parameters are not loaded
A	Green	Lighting / off	HIN work normally/ abnormally
F	Red	Light / off	Fault/ Running normal
Indicator Light 1-32	Green	Light / off	Current state of input is 1/ Current state of input is 0

**The working state corresponding to the indicator LED is as follows:**

- P: Power Indicator LED. The LED is on when the module is powered on . The LED will go off when the module is powered off.
- R: Run Indicator LED. When the module is running normal, the green LED flickers. If the green LED is always on, that means program has been running but parameter is unloaded.
- A: Communication Indicator LED. When CPU module can communicate normally with other modules through HIN, the LED is on.
- F: Fault Indicator LED. The LED is on when the module has fault. The LED will go off when everything is normal.
- 1-32 Channel Indicator LED: Every green light shows state of one input signal. For digital input module, when the light is on, it means the current state of the input signal is 1, otherwise it is 0.

**Technical Specification**

Points	32	
Module Load	450mA/5V	
Power Consumption	2.25W	
Output Voltage	24VDC	
Output Type	Transistor, source type	
Continuous current per channel	0.5A	
Maximum load current (0~40□)	0.6A, 100ms	
Minimum load current (0~40□)	5mA	
Switching Frequency	Resistive Loading	100Hz
	Inductive Loading	0.5 Hz
Installing Size (width×height×depth mm)	32×110×97	
Weight	180g	
Operating Temperature	-10~60□	
Status Indicator	Green indicator LED for each digital input point	
Self Diagnosis Function	Yes	
Insulation Test	500VDC	
Channel Separation	Adjacent Channel Isolation	Yes
	Isolation between Channel and Backplane	Yes, optical isolation

# 5 Analog I/O Module

## □ Synopsis

AI module has two types: current/voltage mode AI module and RTD mode AI module. AO module is current/voltage type.

This chapter will introduce the following subjects:

- 1、 Introduction of available Analog modules
- 2、 The most important characteristics of Analog module
- 3、 Appearance and Wiring schematic of Analog module

## □ Content

Section	Content
5.1	Current/voltage mode AI module AIM301-0801
5.2	RTD mode AI module AIM301-0805
5.3	Thermocouple mode AI module AIM301-0806
5.4	Current/voltage mode AO module AOM301-0401

NA300 series PLC provides many kinds of analog expand modules for users. For more information, please see List 5.1.

### List 5.1 Analog Module

Type	Content	Specifications
AIM301-0801	8 channel AI module	AI8×current/ voltage, single ended
AIM301-0805	8 channel RTD module	AI8×RTD
AIM301-0806	8 channel Thermocouple module	AI8×TC
AOM301-0401	4 channel AO module	AO4×current/ voltage

## 5.1 Analog Input module AIM301-0801:

### AI8×current/voltage

#### Order Number

300AIM3010801

**Features:**

1. 8 channel current mode AI module.
2. Measurement accuracy is 16 bit.
3. Signal form: Single-ended input.
4. Intelligent module with self-diagnosis function can be reset and reboot automatically when fault.
5. No need for hardware setting. The CPU Module can load parameters on it automatically after start up.
6. Hot plugging support.

**Diagram of Interface**

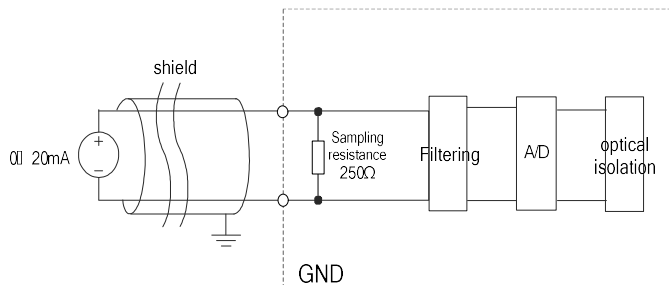

**Diagram of AIM301-0801 Single Channel Interface Circuit**

After transformed by current-voltage device and a filtering circuit, the current signal is transformed into digital signal by A/D device. The digital signal gets through an optical isolation, and then will be read by a microprocessor. The microprocessor uploads the data to master controller through high speed internal bus at last.

**Terminal wiring diagram**

AIM301-0801 AI module connects with external devices by terminal blocks in front of module. Correspondence of each channel is described in the following drawing. And please pay attention to the following:

- Each field AI signal is connected to terminals by two wires (shielded cable).
- Even-numbered terminals connect to negative pole of current signals, odd-numbered terminals connect to positive pole of current signals.
- When the Nth channel is connected to the current type signal, you need to short the RNA and RNB terminals. If connecting voltage mode signals, there is no need to be shorted, and please refer to the following wiring diagram.

- Do not supply power to transmitter with input channel. A separate 24V DC power supply must be used when a two-wired transmitter is connected.
- Prohibition of wiring: “1”、 “2” 、 “19”、 “20”.

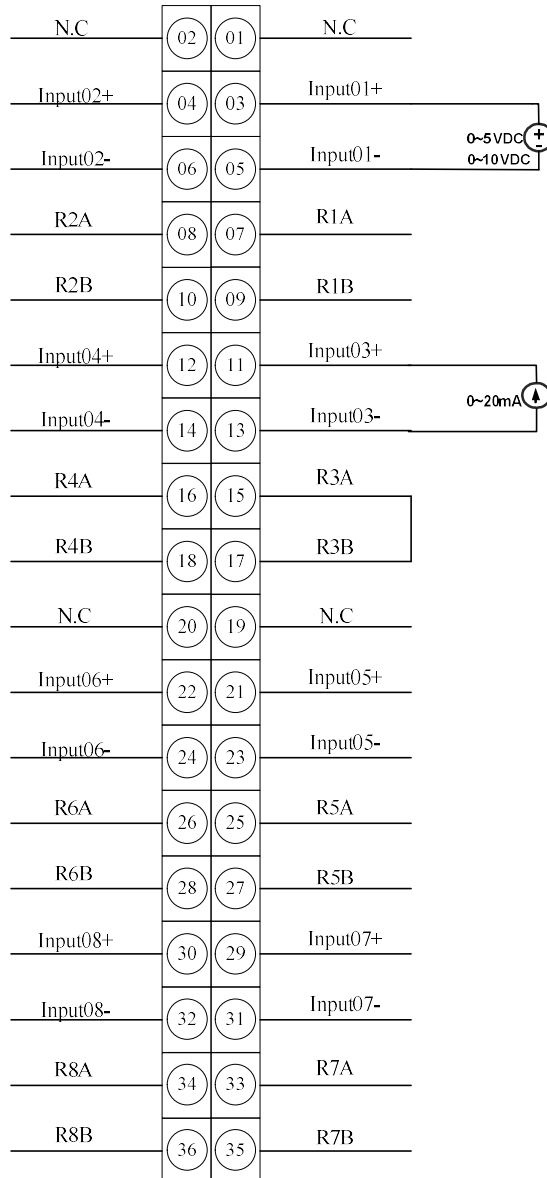

**AIM301-0801 Terminal wiring diagram**

**Module display area description:**

The status indication for the AIM301-0801 module is located directly above the module's front panel. As shown below, using four LED lights and an OLED screen to

display the analog module information. The four LEDs are power indicator P, run indicator R, communication status indicator A and fault indicator F. OLED screen is used to display the voltage or current value collected by the channel.

As shown below:

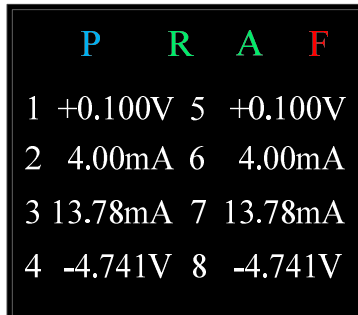

**Module display area diagram**

LED	Color	State	Meaning
P	Blue	Constant Lighting/ off	Power on/ Power off
R	Green	Flicker/Constant Lighting	Run normally/ Program has been running but parameter is unloaded
A	Green	Constant Lighting/ off	HIN work normally/ abnormally
F	Red	Light / off	Fault/ Running normal

**The working state corresponding to the indicator LED is as follows:**

- P: Power indicator LED. When module power on ,the LED is on; When module power off ,the LED is off;
- R: Run indicator LED. When the module is running normal, the green LED flickers. If the green LED is always on, that means program has been running but parameter is unloaded.
- A: Communication indicator LED. When CPU module can communicate normally with other modules through HIN, the LED is on.
- F: Fault indicator LED. The LED is on when the modules has fault. The LED will go off when everything is normal.
- OLED screen: Display the analog value of each channel.

**Technical Specification**

The number of channels	8
Power Consumption	1.9W/5V
Signal Type	-10~10V (0~20000) 0~5V (0~20000) -5~5V (0~20000) 1~5V (4000~20000) 0~10V (0~20000) 4~20mA (4000~20000) 0~20mA (0~20000) 0~10mA (0~20000)
Data Type	0~20000
Maximum Current	20mA
Working Limit Within Temperature Range	0.2%
Precision Acquisition	0.2%
Sampling Period	30ms/each channel
CMRR	>90dB
DMRR	>45dB
Zero Drift Compensation	Each channel can be compensated by software program separately
Self-diagnosis	Yes
Insulation	500V DC
Dimension W×H×D	32×110×97
Weight	140g
Operating Temperature	-10~60□

## 5.2 Analog Input module AIM301-0805: AI8×RTD

### Order Number

300AIM3010805

### Features:

1. 8 channel, RTD temperature probe input.

2. The type of thermistor for each channel can be set optionally.
3. Measurement of each channel: RTD.
4. Wiring mode: Two-wire、Three-wire.
5. Measurement accuracy is 24 bit.
6. Intelligent module with self-diagnosis function can be reset and reboot automatically when fault.
7. No need for hardware setting. The CPU Module can load parameters on it automatically after start up.
8. Hot plugging support.

### Diagram of Interface

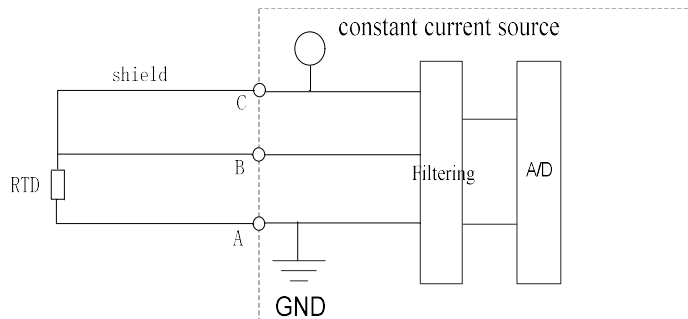

### Diagram of AIM301-0805 Single Channel Interface Circuit

The use of constant current source incentive measurement method, comparative to the traditional electrical bridge measurement, can be more effective in eliminating the impact of measurement accuracy which is caused by line resistance of RTD long wire when electrical bridge is in the state of imbalance. Of course, both the constant current source and electrical bridge measurement methods require an equal value of line resistance of 3 RTD wires, otherwise wire resistance deviation will affect the measurement accuracy.

### Terminal wiring diagram

AIM301-0805 AI module connects with external devices by terminal blocks in front of module. Correspondence of each channel is described in the following drawing. And please pay attention to the following:

- Each field RTD resistance connects to the terminals A, B, C with three separate wires (shielded cable).

- "3,5,7,9", "4,6,8,10" are the input terminals for the first and the second channel of temperature signals, and please see the terminal wiring diagram for other signal wiring method.
- If the resistance which is provided by user is of two-wire, B, C terminals of input channels need to be shorted.
- Please don't connect more than 2 cables to the same pin of the terminal.

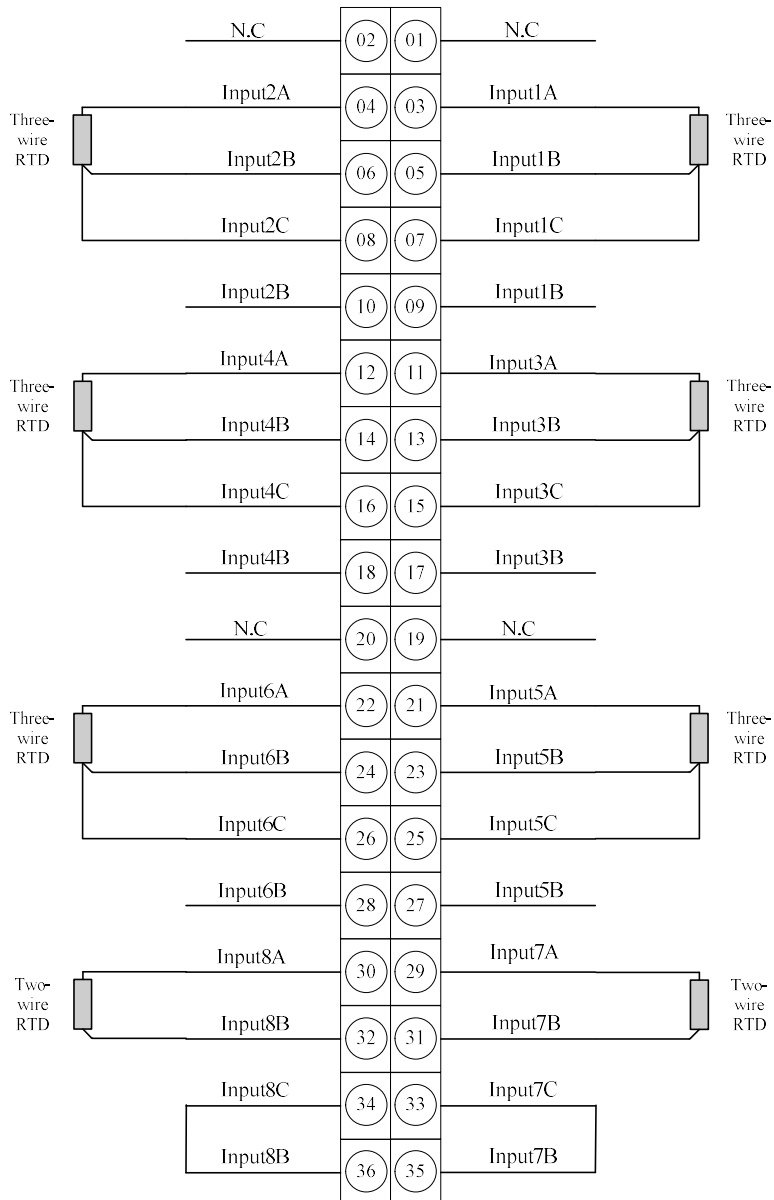

**AIM301-0805 Terminal wiring diagram**

**Display area description:**

The status indication for the AIM301-0805 module is located directly above the module's front panel. As shown below, display the RTD module information with 4 LED indicators and an OLED screen. The four LEDs are the power indicator P, the operation indicator R, the communication status indicator A and the fault indicator F, the OLED screen is used for displaying the measured temperature value of the channel. When the RTD sensor is disconnected from the terminals, the channel will show "ERROR". When the measured value is outside the maximum measuring range, the channel will display "OVER".

As shown below:

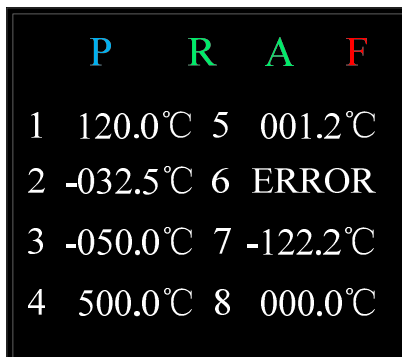

**Module display area diagram**

**Indicator LEDs**

LED	Color	State	Meaning
P	Blue	Constant Lighting/ off	Power on/ Power off
R	Green	Flicker/ Constant Lighting	Run normally/ program has been running but parameter is unloaded
A	Green	Constant Lighting / off	HIN work normally/ abnormally
F	Red	Light / off	Fault/ Running normal

**The working state corresponding to the indicator LED is as follows:**

- P: Power indicator LED. When module power on ,the LED is on; When module power off ,the LED is off.
- R: Run indicator LED. When the module is running normal, the green LED flickers. If the green LED is always on, that means program has been running but parameter is unloaded.

- A: Communication indicator LED. When CPU module can communicate normally with other modules through HIN, the LED is on.
- F: Fault indicator LED. The LED is on when the modules has fault. The LED will go off when everything is normal.
- OLED screen: Display channel corresponding temperature value and fault information.

**Technical Specification**

The number of channels	8
Unit of measurement	□
Power Consumption	2.4W/5V
Signal Type	Pt100, Cu50, Cu53, Cu100, Pt1000, Ni1000
Data Type	Actual value×10 (“ERROR” is displayed when signal offline)
Precision Acquisition	0.1% °C
Linear Error	0.2%
Sampling Period	1s
CMRR	>90dB
DMRR	>45dB
Zero Drift Compensation	Each channel can be compensated by program separately
Self-diagnosis	Yes
Dimension W×H×D	32×110×97
Weight	140g
Operating Temperature	-10~60□

**5.3 Analog Input module AIM301-0806: AI8×thermocouple**  
**Order Number**

300AIM3010806

**Features:**

- 8 channel thermocouple (TC) differential input.
- The type of thermocouple can be set optionally.
- Measurement of each channel: Thermocouple.
- Measurement accuracy is 24 bit.
- Intelligent module with self-diagnosis function can be reset and reboot automatically when fault.
- No need for hardware setting. The CPU Module can load parameters on it automatically after startup.
- Hot plugging support.

### Diagram of Interface

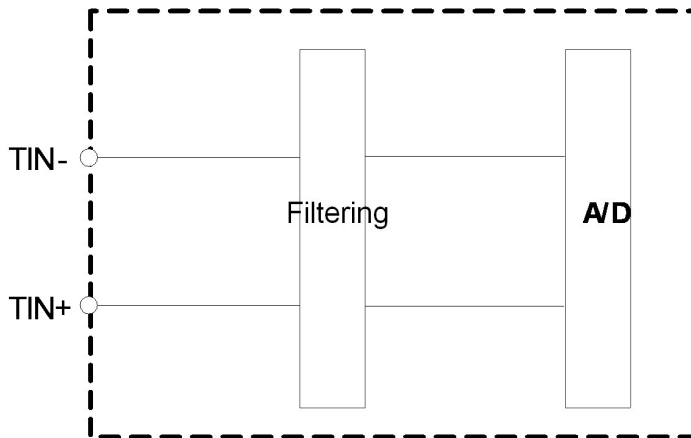
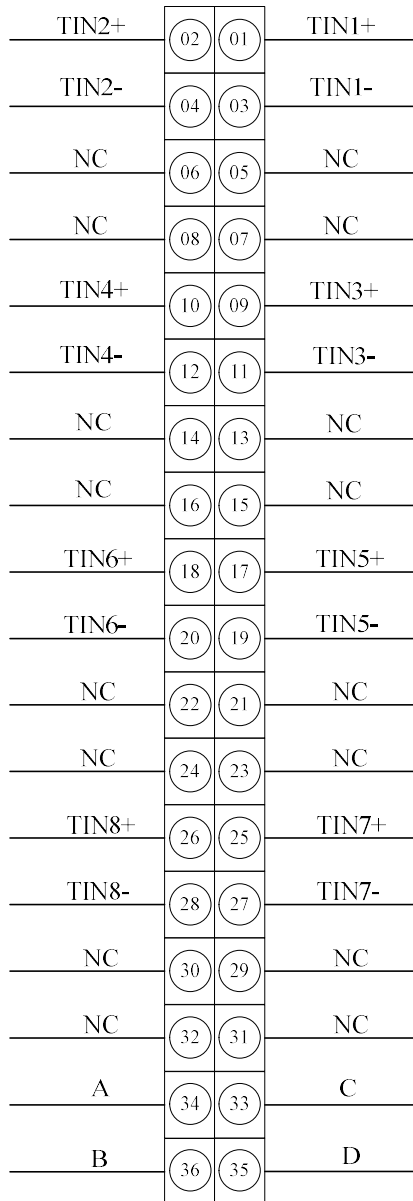

Diagram of AIM301-0806 Single Channel Interface Circuit

### Terminal wiring diagram



**AIM301-0806 Terminal wiring diagram**

**A、B、C、D** is the input of **RTD** for measuring of the temperature of cold Terminal.

**Terminal wiring diagram**

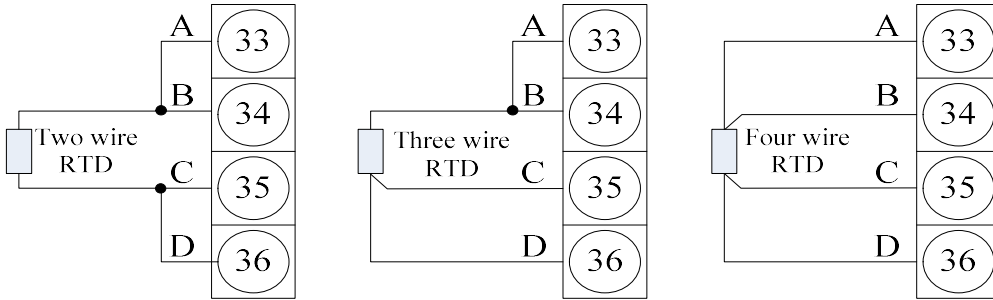

**AIM301-0806 RTD cold Terminal wiring diagram**

**Indicator LED description:**

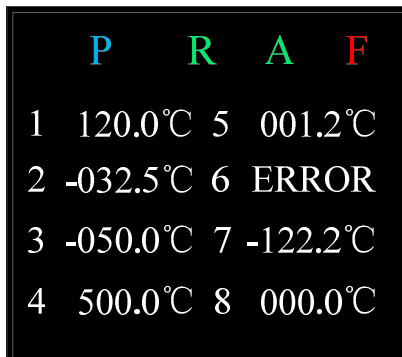

**Module display area diagram**

LED	Color	State	Meaning
P	Blue	Constant Lighting/ off	Power on/ Power off
R	Green	Flicker/ Constant Lighting	Run normally/ program has been running but parameter is unloaded
A	Green	Constant Lighting / off	HIN work normally/ abnormally
F	Red	Light / off	Fault/ Running normal

**The working state corresponding to the indicator LED is as follows:**

- R: Run indicator LED. When the module is running normal, the green LED flickers. If the green LED is always on, that means program has been running but parameter is unloaded.
- A: Communication indicator LED. When CPU module can communicate normally with other modules through HIN, the LED is on.
- F: Fault indicator LED. The LED is on when the modules has fault. The LED will go off when everything is normal.
- OLED screen: Display channel corresponding temperature value and fault

information.

**Technical Specification**

The number of channels	8
Unit of measurement	□
Power Consumption	2W/5V
Signal Type	S、T、R、E、N、J、K
Data Type	Actual value×10 (32767 when signal offline)
Maximum Input Voltage	20VDC
Resolution	24bits
Elementary Error	0.05%FS(Voltage)
Breakwire Sense Leakage Current	≤0.1uA
Working Limit Within Temperature Range	0.2%(for type of S,R and T); 0.1%(for other type):
Sampling Period	150ms/c
Noise Suppression	50Hz/60Hz
CMRR	>90dB
DMRR	>45dB
Zero Drift Compensation	Each channel can be compensated by program separately
Dimension W×H×D	32×110×97
Weight	140g
Operating Temperature	-10~60□
Self-diagnosis	Yes

**TC corresponding relation table**

Signal Type	Actual temperature value (□)	Data Type	Reference temperature (□)
B	0~1800	0~18000	0
N	-200~1300	-2000~13000	0
E	-200~1000	-2000~10000	0
E2	-20~620	-200~6200	0

R	-0~1700	0~17000	0
S	-0~1700	0~17000	0
J	-200~1200	-2000~12000	0
T	-200~400	-2000~4000	0
K	-200~1300	-2000~13000	0
K2	-20~520	-200~5200	0

\* The final value of module collection is the data of increasing cold forging compensation temperature treatment.

## 5.4 Analog Input module AIM301-1602: AI16×current type

### Order number

300AIM301-1602

### Features:

The AIM301-1602 analog input module has the following features:

1. 16-channel current type analog input module;
2. The precision of the measurement is 16 bits;
3. Signal input form: single-ended input;
4. Intelligent module, with self-diagnosis function, can automatically reset and restart when the module fails to operate;
5. The hardware does not need to be set, and the CPU module automatically loads parameters to it after startup;
6. Support hot swap. Schematic diagram of the channel interface circuit

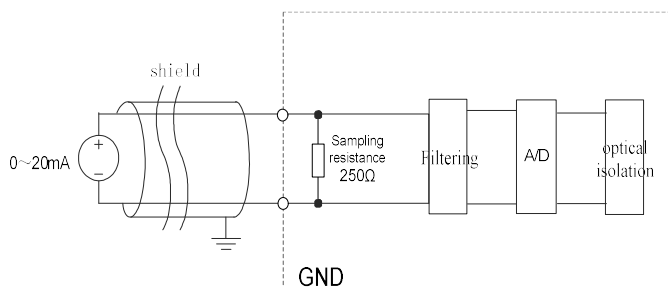

**AIM301-1602 single-channel interface circuit diagram**

The current signal is converted into a digital signal by current-voltage conversion, filtering, and A/D. After photoelectric isolation, the module's micro The processor reads and then uploads to the controller master via the high-speed internal bus.

### **Terminal wiring diagram**

The AIM301-1602 analog input module is wired with external devices through the wiring terminals on the front of the module. The system is shown in the figure below, and please note the following:

1. Each AI signal in the field is connected to the terminal with two wires (shielded cable).

2. The input channel does not supply power to the transmitter, and the field 24V needs to be used separately when connecting a two-wire transmitter. The DC power supply powers the transmitter .

3. "01+", "01-" terminals are 1-channel analog input terminals; "16+", "16-" terminals are 16-channel analog input. Among them, the terminal "N+" (the value range of N is 1~16) is connected to the positive pole of the analog input. Terminal "N-" is connected to the negative pole of analog input (all "N-" are shorted internally).

4. All " NC" terminals are not used, wiring is prohibited.

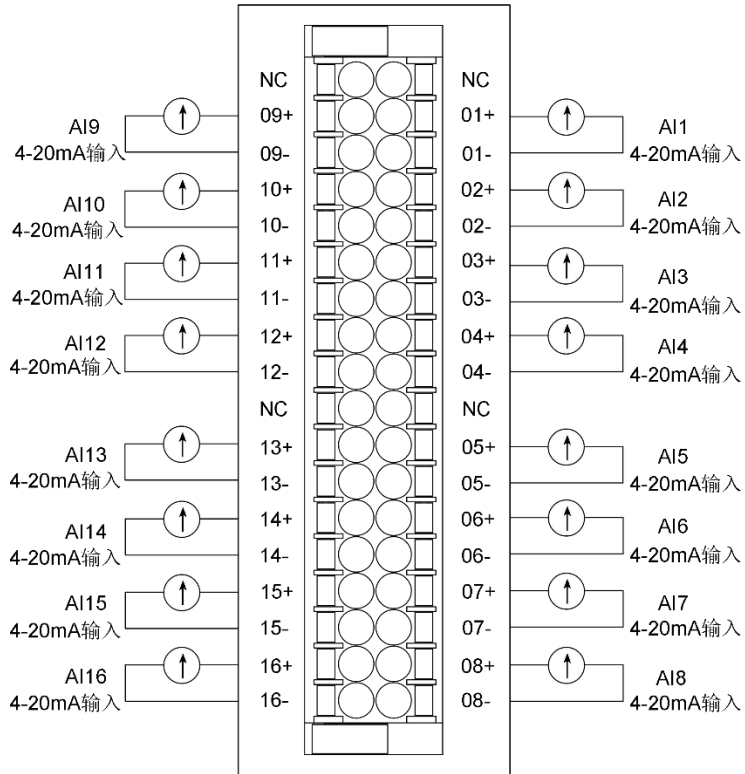

**AIM301-1602 terminal wiring diagram**

**Display area description:**

The status indication of the AIM301-1602 module is located just above the front panel of the module. As shown in the figure below, 4 LED indicators and an OLED screen are used to display the information of the analog module. The 4 LEDs are the power indicator P, running indicator light R, Communication status indicator A and fault indicator F, the OLED screen is used to display the voltage or current value collected by the channel.

As shown below:

P	R	A	F
1 5.10mA	5 5.10mA		
2 4.00mA	6 4.00mA		
3 13.78mA	7 13.78mA		
4 5.10mA	8 5.10mA		

**Schematic diagram of the module display area**

**Indicator LEDs**

LED	Color	State	Meaning
P	Blue	Constant Lighting/ off	Power on/ Power off
R	Green	Flicker/ Constant Lighting	Run normally/ program has been running but parameter is unloaded
A	Green	Constant Lighting / off	HIN work normally/ abnormally
F	Red	Light / off	Fault/ Running normal

**The working state corresponding to the indicator LED is as follows:**

- P: Power indicator LED. When module power on ,the LED is on; When module power off ,the LED is off.
- R: Run indicator LED. When the module is running normal, the green LED flickers. If the green LED is always on, that means program has been running but parameter is unloaded.
- A: Communication indicator LED. When CPU module can communicate normally with other modules through HIN, the LED is on.
- F: Fault indicator LED. The LED is on when the modules has fault. The LED will go off when everything is normal.
- OLED screen: Display channel corresponding temperature value and fault information.

**Technical Specification**

number of channels	16	
Power consumption	1.9W/5V	
signal type	0 ~ 20mA 0 ~ 10mA	4 ~ 20mA
Data Format	0 ~ 20000	4000 ~ 20000
Maximum input current	20mA	
Operating Limits Over the Entire Temperature Range	0.2%	
Acquisition accuracy	0.2%	
The sampling period	30ms/channel	
Common Mode Rejection Ratio	>90dB	
Differential Mode Rejection Ratio	>45dB	
Zero drift compensation	Each channel can be individually compensated by software	
Self-diagnostic function	Have	
Insulation test	500V DC	
Dimensions (W×H×D) (mm)	32×110×97	
weight	140g	
Operating temperature	-25~65°C	

## 5.5 Analog Output module AOM301-0401:

## **AO4×current/voltage**

### **Order Number**

300AOM3010401

### **Features:**

1. 4 channel current/voltage output.
2. Output range of each channel: Voltage output:0~5V、1~5V、-5V~5V、0V~10V 、-10V~10V; Current output:4~20mA、0~20mA、0~10mA
3. Measurement accuracy is 16 bit.
4. Intelligent module with self-diagnosis function can be reset and reboot automatically when fault.
5. Each AO channel has a corresponding OLED display.
6. No need for hardware setting. The CPU Module can load parameters on it automatically after start up.
7. Hot plugging support.
8. Error mode output status, maintain the last state or user-defined value.

### **Diagram of Interface**

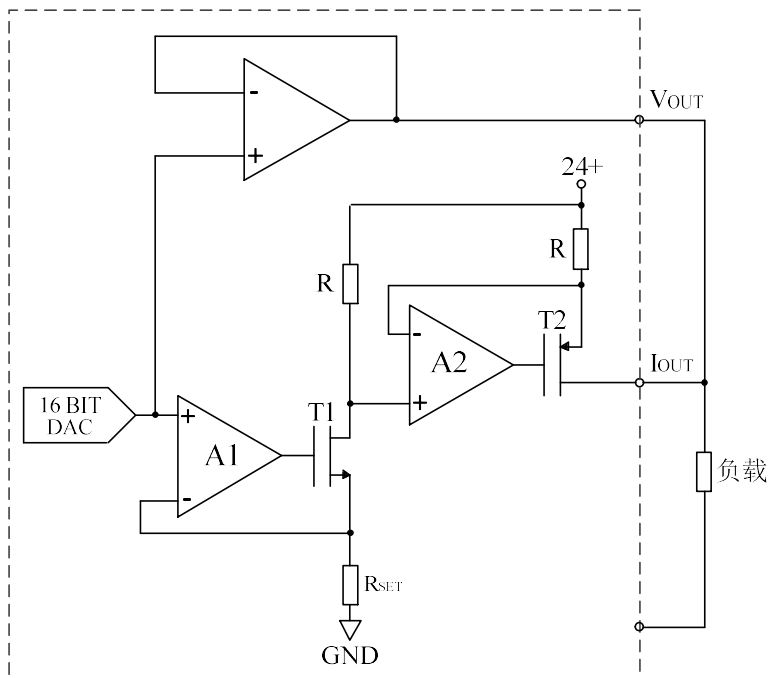

**Diagram of AOM301-0401 Single Channel Interface Circuit**

**Terminal wiring diagram**

AOM301-0401 AO module connects with external devices by terminal blocks in front of module. Correspondence of each channel is described in the following drawing.

And please pay attention to the following:

- Each field AO output signal connects to the load respectively by two wires (shielded cable).
- Even-numbered terminals connect to negative pole of current signals ,  
Odd-numbered terminals connect to positive pole of current signals.

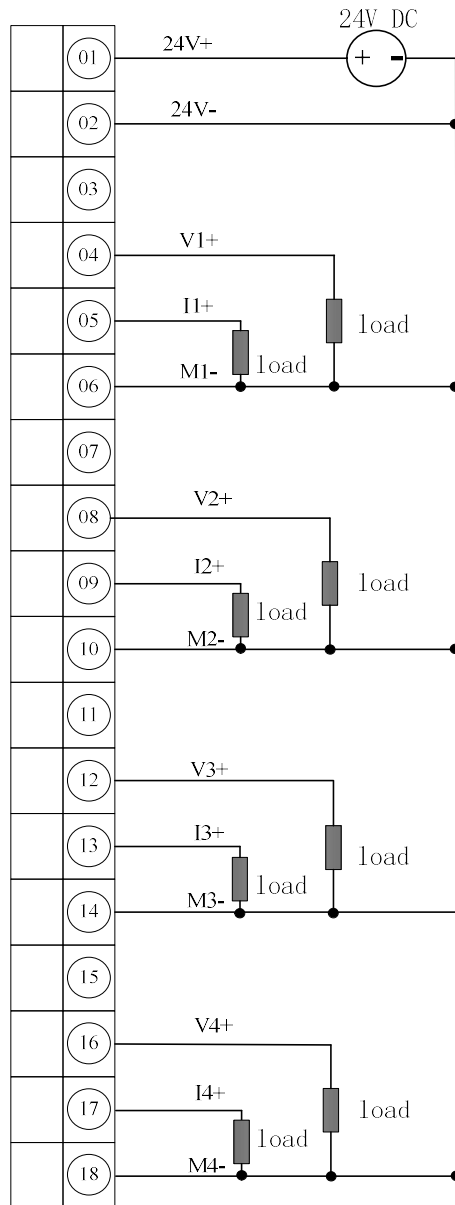

**AOM301-0401 Terminal wiring diagram**

**Display area description:**

The status indication for the AIM301-0401 module is located directly above the module's front panel. As shown below, display the RTD module information with 4 LED indicators and an OLED screen. The four LEDs are the power indicator P, the operation indicator R, the communication status indicator A and the fault indicator F,

OLED screen is mainly used to display the 4-channel output analog value and fault information.

**Indicator LED description:**

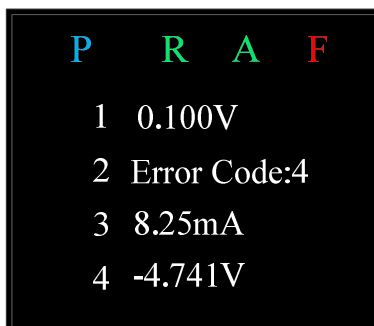

**Display area diagram**

**Indicator LEDs**

LED	Color	State	Meaning
P	Blue	Constant Lighting/ off	Power on/ Power off
R	Green	Flicker/Constant Lighting	Run normally/ program has been running but parameter is unloaded
A	Green	Constant Lighting / off	HIN work normally/ abnormally
F	Red	Light / off	Fault/ Running normal

**The working state corresponding to the indicator LED is as follows:**

- P: Power indicator LED. When module power on ,the LED is on; When module power off ,the LED is off.
- R: Run indicator LED. When the module is running normal, the green LED flickers. If the green LED is always on, that means program has been running but parameter is unloaded.
- A: Communication indicator LED. When CPU module can communicate normally with other modules through HIN, the LED is on.

- F: Fault indicator LED. The LED is on when the module external 24VDC is abnormal. The LED will go off when everything is normal.
- OLED screen display: Corresponding to the voltage and current values of four channels, If the signal is voltage then the data show three decimal places, If the signal is current, then the data shows two decimal places. When external 24VDC is abnormal, OLED screen displays "NO 24V POWER". When the module has other faults, the corresponding channel displays Error Code: 4, Error Code: 2, Error Code: 1. The meaning of the error is shown in the following table.

**Error code definition:**

Error code	Meaning
NO 24V POWER	External 24V is abnormal
Error Code:4	Corresponding channel, a fault is detected on the IOOUT pin
Error Code:2	Corresponding channel, the output value of the pressure swing effective
Error Code:1	Corresponding channel, the chip core temperature exceeds 150 °C

**Technical Specification**

The number of channels		4
Power Consumption		2.6W/5V
Output Type		Current, Voltage
Output Range		-10~10V (0~20000) 0~5V (0~20000) -5~5V (0~20000) 1~5V (4000~20000) 0~10V (0~20000) 4~20mA (4000~20000) 0~20mA (0~20000) 0~10mA (0~20000)
Load Resistance	Current	<1000Ω
	Voltage	>2000Ω
Output Error		0.2%
Linear Error		0.05%
Conversion Time (each channel)		Maximum 0.8ms
Setup Time	Resistive Load	0.2 ms
	Capacitive Load	3.3 ms
	Inductive Load	0.5 ms(1mH)
Limit damage of plus current		Maximum DC50mA
Maximum open circuit voltage		24V
Self-diagnosis		Yes
Isolation	Between Channels	Yes
	Between Channel and Backplane	Yes
Dimension W×H×D		32×110×97

NA300 Series Programmable Logic Controller Technical Specifications and User Manual

Weight	140g
--------	------

## 6 High Speed Count Module

### □ Synopsis

HCM301 , an intelligent count module, is widely used in count and measurement . It has direct-connect Gate signal capture 24-V incremental encoder、Orientation sensor、Starter and pulse of NAMUR encoder. This module can share the tasks of CPU by ways as follow:

- 1.direct connect to 24-V incremental encoder and NAMUR encoder
- 2.direct connect gated signal by Wire digital inputs
- 3.Comparison function and respond by Wire digital outputs

### □ Content

Section	Content
6.1	High speed count module 3 channel, SSI absolute value module
6.2	High speed count module 8 channel (100kHz@5 VDC, 35kHz@24VDC)

### 6.1 High-Speed Count Module HCM301-0302

#### Order Number

300HCM301 - 0302

#### Main Characters

The HCM301-0302 high-speed counting module has the following features:

- Support 3-channel SSI encoder input;
- Support 8-bit to 31-bit encoder;
- Support 4 baud rates (100 kHz, 200 kHz, 500 kHz, 1MHz);
- Support independent two-input capture of each channel encoder;
- Supports programmable filtering of captured signals;
- Support hardware parity;

- Supports 1 reflection output based on the comparison result of each channel;
- The hardware cycle obtains the position value of the SSI encoder, and the fixed cycle is 1ms;
- Hot plugging.

**Module outlook**

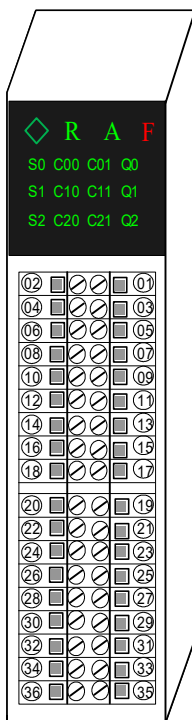

**NA300HCM301-0302 High-speed counting modul**

**Module Light Definition**

The following table describes the NA400HCM301-0302 SSI module led Display area indicator lights and their working status:

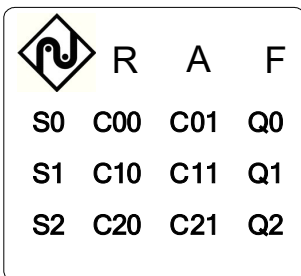

**Indicator LEDs**

Led	Color	Status	Meaning
R	green	flashing / constant light	Module normal operation / module failure
A	green	ON/OFF	The module is sending data normally in the internal network /sending data abnormally
F	red	ON/OFF	The light is on to indicate that the module is faulty / the light is off during normal operation
S0	green	ON/OFF	The 1st channel SSI encoder has normal input/no normal input
C00	green	ON/OFF	Channel 1 captures 0 signal level state, high/low level
C01	green	ON/OFF	Channel 1 captures 1 signal level state, high/low level
Q0	green	ON/OFF	Channel 1 reflected output signal level status, high/low level
S1	green	ON/OFF	The 2nd channel SSI encoder has normal input/no normal input
C10	green	ON/OFF	Channel 2 captures 0 signal level state, high/low level

C11	green	ON/OFF	Channel 2 captures 1 signal level state, high/low level
Q1	green	ON/OFF	Channel 2 reflected output signal level status, high/low level
S2	green	ON/OFF	The 3rd channel SSI encoder has normal input/no normal input
C20	green	ON/OFF	Channel 3 captures 0 signal level state, high/low level
C21	green	ON/OFF	Channel 3 captures 1 signal level state, high/low level
Q2	green	ON/OFF	Channel 3 reflected output signal level status, high/low level

### SSI interface

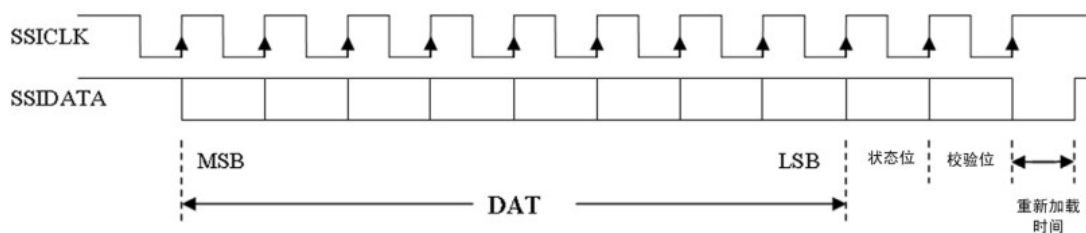

The following are other characteristics of frames and interfaces:

Parameter	Value
code	Binary or gray code
SSI transmits baud rate data bits	100 kHz, 200 kHz, 500 kHz or 1 MHz
data bits	8 to 31 bits
status bit	0 to 1 bits
check	Even, odd or no parity

The data bits parameter declares the number of data bits (from MSB to LSB)

provided by the encoder. The upper limit is 31.

The status bit is a status flag that is refreshed when this bit is received in the sequence. For some encoders, this bit can indicate errors detected in the data frame.

Parity bit can be declared in the frame via the parity parameter . If a parity bit is selected, the module performs a parity check based on the selected parity type (even or odd).

The baud rate parameter has four choices that affect the maximum cable length:

Baud rate	100kHz	200kHz	500kHz	1MHz
Maximum Cable Length	350m	180m	70m	20m

**Terminal Wiring Definition**

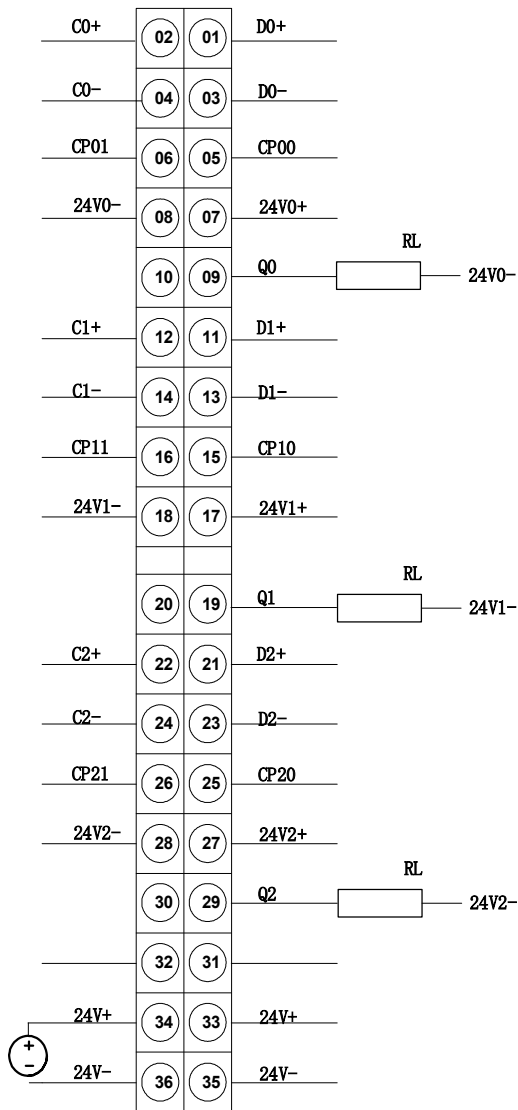

Pin Name	Function	Remark
D0 +, D 1+, D2+	SSI encoder DATA+ signal	
D0-, D1-, D2-	SSI encoder DATA-signal	
C0+, C1+, C2+,	SSI encoder CLK+ signal	
C0-, C1-, C2-,	SSI encoder CLK-signal	
CP00, CP10, CP20	1st capture input	ON: +11~+30 Vdc

		OFF: <5Vdc
CP01, CP11, CP21	2nd capture input	
Q0, Q1, Q2	Reflected output	source output
24V0+, 24V1+, 24V2+,	Encoder 24V+ power input	
24V0-, 24V1-, 24V2-	Encoder 24V-power ground input	
24V+	This module is externally connected to the positive input of 24V power supply	19.2~30V
24V-	This module is externally connected to the negative input of 24V power supply	

### Module Specifications

Module	NA400HCM301-0302 SSI module
Order Number	NA400HCM301-0302
Power Consumption	3.0W/5V
Current Consumption	600mA/5V
Number of SSI Channels	3
Bit Width	8 to 31 bits
Support Common Baud Rate	100kHz, 200kHz, 500kHz, 1MHz
Refresh Interval	= 1 ms
Support Hot plugging	Yes
Encoder Compliance	Absolute encoder 24 V version with standard SSI

	interface (tolerance: 19.2-30 Vdc)
Encoder Power	Voltage: 24 VDC (powered by this module)
Weight	250g
Dimensions (W×H×D) (mm)	40×145×162

## 6.2 High-Speed Count Module HCM301-0801

### Order Number:

300HCM301-0801

### Features:

- Support 8 single-phase high-speed counting inputs;
- Support 4-way dual-phase high-speed counting input;
- Support independent 8 -channel capture;
- Supports programmable filtering of captured signals;
- Supports 8 counting modes: frequency measurement mode, event counting mode, return-to-zero counting mode, ring counting mode, single- phase addition and subtraction counting mode, dual-phase addition and subtraction counting mode, dual-phase direction counting mode, and dual-phase AB counting mode;
- Support hot swap. module appearance

### Outlook of HCM301-0801 module

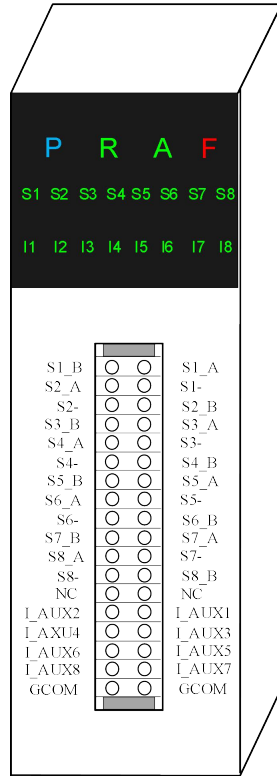

**NA300HCM301-0801 High-speed counting modul**

**Module light definition**

The following table describes the LED display area indicators of the NA300HCM301-0801 module and their working status:

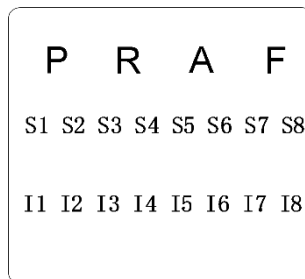

**LED display area indicator**

Led	Light	Light Status	Meaning
-----	-------	--------------	---------

	Color		
R	green	flashing/constant light	Module normal operation / module failure
A	green	ON/OFF	The module is sending data normally in the internal network /sending data abnormally
F	red	ON/OFF	The light is on to indicate that the module is faulty / the light is off during normal operation
S1	green	flashing/off	Channel 1 pulse signal S1_A(B)/S1-differential signal, the light will flash when there is a pulse
S2	green	flashing/off	Channel 2 pulse signal S2_A(B)/S2-differential signal, the light will flash when there is a pulse
S3	green	flashing/off	Channel 3 pulse signal S3_A(B)/S3-differential signal, the light will flash when there is a pulse
S4	green	flashing/off	Channel 4 pulse signal S4_A(B)/S4-differential signal, the light will flash when there is a pulse
S5	green	flashing/off	Channel 5 pulse signal S5_A(B)/S5-differential signal, the light will flash when there is a pulse
S6	green	flashing/off	Channel 6 pulse signal S6_A(B)/S6-differential signal, the light will flash when there is a pulse
S7	green	flashing/off	Channel 7 pulse signal S7_A(B)/S7-differential signal, the light will flash when there is a pulse
S8	green	flashing/off	Channel 8 pulse signal S8_A(B)/S8-differential signal, the light will flash when there is a pulse
I1	green	ON/OFF	Channel 1 function input signal I_AUX1 input level, high/low level

12	green	ON/OFF	Channel 2 function input signal I_AUX2 input level, high/low level
13	green	ON/OFF	Channel 3 function input signal I_AUX3 input level, high/low level
14	green	ON/OFF	Channel 4 function input signal I_AUX4 input level, high/low level
15	green	ON/OFF	Channel 5 function input signal I_AUX5 input level, high/low level
16	green	ON/OFF	Channel 6 function input signal I_AUX6 input level, high/low level
17	green	ON/OFF	Channel 7 function input signal I_AUX7 input level, high/low level
18	green	ON/OFF	Channel 8 function input signal I_AUX8 input level, high/low level

**Module Specifications**

Model	NA300HCM301-0801 High-speed counting module
order number	300HCM301-0801
Power consumption	3.0W/5V
current consumption	600mA/5V
Number of high-speed counting channels	8
Support common baud rate	10~100 kHz
Support hot swap	Yes

weight	140g
Dimensions ( W × H × D ) ( mm)	32 × 110 × 97

### Terminal wiring diagram

The HCM301-0801 high-speed counting module is wired with external devices through the wiring terminals on the front of the module, and the corresponding relationship of each channel As shown in the image below, and please note the following:

1. Each signal in the field is connected to the terminal with two wires (shielded cable).
2. "Sn\_A" is the 24V input terminal of n (the value range of n is 1-8) channel, "Sn\_B" is the 5V input of n channel terminal, "Sn-" is the negative terminal of the n channel. When the n-channel input is 24V, connect the terminals "Sn\_A", "Sn-"; when the n-channel input is 5V, connect the terminals "Sn\_B" and "Sn-".
3. "I\_AUX1", "I\_AUX2", "I\_AUX3", "I\_AUX4", "I\_AUX5", "I\_AUX6", "I\_AUX7" and "I\_AUX8" terminals are the function signal input channels 1 to 8 respectively.
4. " NC" terminal is not used, wiring is prohibited.

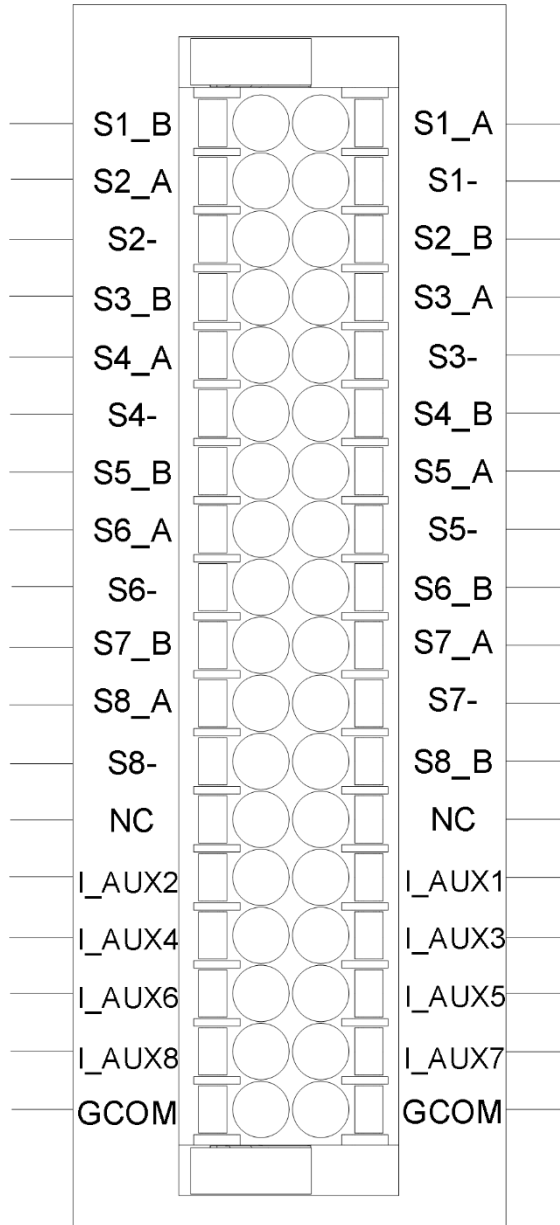

**NA300HCM301-0801 Terminal wiring diagram**

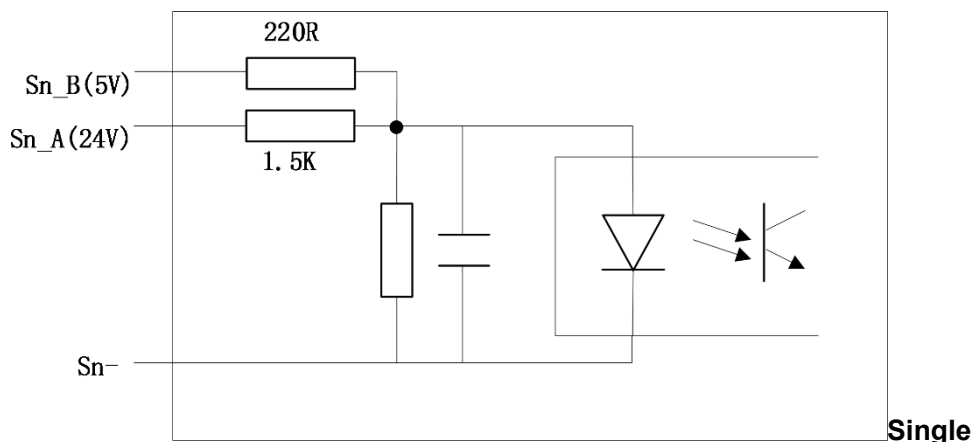

**Channel Wiring Schematic**

**NA300HCM301-0801 Single Channel Wiring Schematic**

Note: Taking the nth channel (the value range of n is 1 to 8) as an example, when the input signal is 24V, the positive terminal of the input signal is input to the terminal. Sub Sn\_A, the negative terminal is connected to the terminal Sn-; when the input signal is 5V, the positive terminal of the input signal is input to the terminal Sn\_B, and the other terminal is connected to Terminal Sn-.

pin name	Function	Remark
S1_A/A1+	channel 1 Pulse input signal S1_A (24 V) , positive terminal	channel 1 A1+ input (24V) of two-phase counting , positive terminal
S1_B/A1+	channel 1 Pulse input signal S1_B (5 V) , positive terminal	channel 1 A1+ input (5V) of two-phase counting , positive terminal
S1-/A1-	channel 1 Pulse input signal S1- , negative terminal	channel 1 A1- input of double-phase counting , negative terminal
S2_A/B1+	channel 2 Pulse input signal S2_A (24 V) , positive terminal	channel 1 B1+ input (24V) of two-phase counting , positive terminal
S2_B/B1+	channel 2 Pulse input signal S2_B (5 V) , positive terminal	channel 1 B1+ input (5V) of two-

	V) , positive terminal	phase counting , positive terminal
S2-/B1-	channel 2 Pulse input signal S2- , negative terminal	channel 1 B1 -input of bi-phase counting , negative terminal
S3_A /A3+	channel 3 Pulse input signal S3_A (24 V) , positive terminal	channel 3 A3+ input (24V) of two- phase counting , positive terminal
S3_B /A3+	channel 3 Pulse input signal S3_B (5 V) , positive terminal	channel 3 A3+ input (5V) of double-phase counting , positive terminal
S3-/A3-	channel 3 Pulse input signal S3- , negative terminal	channel 3 A3 -input of double-phase counting , negative terminal
S4_A/B3+	Channel 4 Pulse input signal S4_A (24 V) , positive terminal	channel 3 B3+ input (24V) of two- phase counting , positive terminal
S4_B/B3+	Channel 4 Pulse input signal S4_B (5 V) , positive terminal	channel 3 B3+ input (5V) for bi-phase counting , positive terminal
S4-/B3-	Channel 4 Pulse input signal S4- , negative terminal	channel 3 B3- input of bi-phase counting , negative terminal
S5_A/A5+	Channel 5 Pulse input signal S5_A (24 V) , positive terminal	Channel 5 A5+ input (24V) of two- phase counting , positive terminal
S5_B/A5+	Channel 5 Pulse input signal S5_B (5 V) , positive terminal	Channel 5 A5+ input (5V) of double-phase counting , positive terminal
S5-/A5-	Channel 5 Pulse input signal S5- , negative terminal	Channel 5 A5- input of double-phase counting , negative terminal
S6_A/B5+	Channel 6 Pulse input signal S6_A (24 V) , positive terminal	Channel 5 B5+ input (24V) of two- phase counting , positive terminal

S6_B/B5+	Channel 6 Pulse input signal S6_B (5 V) , positive terminal	Channel 5 B5+ input (5V) of two-phase counting , positive terminal
S6-/B5-	Channel 6 Pulse input signal S6- , negative terminal	Channel 5 B5- input of bi-phase counting , negative terminal
S7_A/A7+	Channel 7 Pulse input signal S7_A (24 V) , positive terminal	Channel 7 A7+ input (24V) of two-phase counting , positive terminal
S7_B/A7+	Channel 7 Pulse input signal S7_B (5 V) , positive terminal	Channel 7 A7+ input (5V) of double-phase counting , positive terminal
S7-/A7-	Channel 7 Pulse input signal S7- , negative terminal	Channel 7 A7 -input of double-phase counting , negative terminal
S8_A/B7+	channel 8 Pulse input signal S8_A (24 V) , positive terminal	Channel 7 B7+ input (24V) of two-phase counting , positive terminal
S8_B/B7+	channel 8 Pulse input signal S8_B (5 V) , positive terminal	Channel 7 B7+ input (5V) for bi-phase counting , positive terminal
S8-/B7-	channel 8 Pulse input signal S8- , negative terminal	Channel 7 B7 -input of bi-phase counting , negative terminal
I_AUX1	channel 1 Function signal input	
I_AUX2	channel 2 Function signal input	
I_AUX3	channel 3 Function signal input	
I_AUX4	Channel 4 Function signal input	
I_AUX5	Channel 5 Function signal input	
I_AUX6	Channel 6 Function signal input	
I_AUX7	Channel 7 Function signal input	
I_AUX8	channel 8 Function signal input	

GCOM	I_AUX , externally grounded	
------	-----------------------------	--

## 7 Communication Module

### Synopsis

NA300 controllers support communication protocols to communicate with third party local intelligent devices, such as MODBUS, PROFIBUS-DP, Ethernet and so on. If NA300 control system is to provide a certain communication function, this can be achieved by simply installing an appropriate communication module on the backplane. Various types of communication modules can cover most popular network protocols, so that traditional field control devices could improve their communication ability.

### Content

Several kinds of CMM modules are described in this chapter.

Section	Content
7.1	Serial Communication Module CMM301-0401
7.2	Profibus DP Slave Communication Module CMM301-0103
7.3	Double CAN Module CMM301-0204
7.4	Ethernet Substation Module CMM301-0118
7.5	Profinet Slave Module CMM301-0401
7.6	CANOpen Master Module CMM 301-0104

NA300 PLC provides different types of communication modules for user choice.

Please see Table 7.1 for detailed information.

Table 7.1 Communication Modules List

Type	Name	Content
CMM301-0401	Serial Communication Module	4 × RS485
CMM301-0103	Profibus DP Slave Communication Module	DP Slave

CMM301-0204	Double CAN Module	Two way of CAN interface
CMM301-0118	Ethernet Substation Module CMM301-0118	Ethernet Substation
CMM301-0109	Profinet Slave Module CMM301-0401	Profinet Slave Module

## 7.1 Serial Communication Module CMM301-0401

### Order Number

300CMM3010401

### Features:

1. It can expand up to four external serials.
2. Serial ports of RS485 type.
3. Programmable serial interface driver.
4. Independently accomplishing serial communication task, only exchanging data with CPU without requiring CPU resource.
5. Different from the network of I/O modules, data exchange with CPU uses a separate internal network, so as to lower the load of internal network.
6. The maximum of communication nodes is 32 when using RS-485 converter.
7. Intelligent module with self-diagnosis function can be reset and reboot automatically when fault.
8. No need for hardware setting. The CPU Module can load parameters on it automatically after start up.
9. Hot plugging support.

**Outlook**

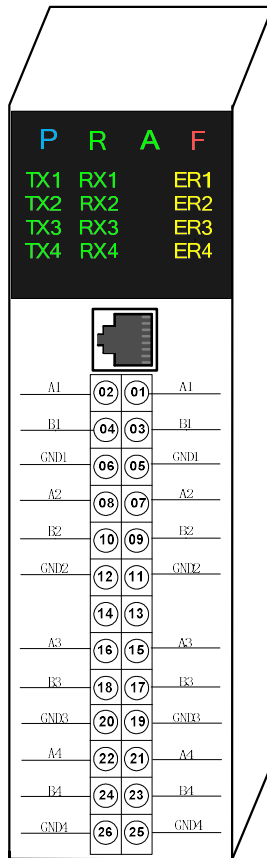

**CMM301-0401**

**Indicator LED description:**

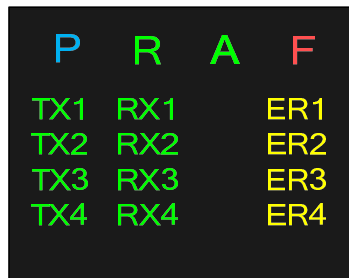

**Indicator LEDs**

LED	Color	State	Function
P	Blue	Light/ off	Power on / off
R	Green	Flicker/ Constant Lighting	Run normally/ program is running but parameters are not loaded
A	Green	Light/ off	HIN work normally/ abnormally
F	Red	Light/ off	Fault/ Running normally
TX1~TX4	Green	Light/ off	Serial port is sending data/No Data is
RX1~RX4	Green	Light/ off	Serial port is receiving data/No Data is receiving
ER1~ER4	Yellow	Light/ off	Serial port is faulty/ normal

**The working state corresponding to the indicator LED is as follows:**

- P: Power indicator LED. Light up when the module is powered on and off when powered off.
- R: Run indicator LED. When the module is running normal, the green LED flickers. If the green LED is always on, that means program has been running but parameter is unloaded.
- A: HIN Active Indicator LED. When HIN works normally, the LED is on, or it turns off.
- F: Fault Indicator LED. The LED is light when the module is fault.
- Tx1~Tx4: Data transmission indicating light for four serial ports (COM1~COM4). The corresponding "Tx" lamp is on when the serial port is sending data.
- Rx1~Rx4: Data receiving indicating lights for four serial ports (COM1~COM4). The corresponding "Rx" lamp is on when the serial port is receiving data.

- ER1~ER4: Data transmission or receiving abnormal indicating lights for four serial ports (COM1~COM4). The corresponding “ER” lamp is on when the serial port is sending or receiving data abnormal.

### Technical Specification

CMM type	CMM301-0401
Order NO.	300CMM3010401
Power Consumption	1.75W/5V
Current Consumption	350mA/5V
Number Of Expansion Serials	4
Type Of The Serial Port	RS485
Baud Rate	2.4~38.4 kbps
Electrical Isolation	RS485 (yes)
Independent Interruption	yes
Communication Program	Programmable mode
Weight	160g
Dimensions W×H×D (mm)	32×110×97

### Hardware Setting and Communication Interface of CMM301-0401

#### 1. Ethernet Interface

The module provides one 10Mbps Ethernet interface with IP address as 192.168.3.100. Debugging program or file transmission can be done through Ethernet.

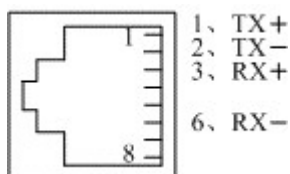

#### 2. How to connect peripheral devices

Communication modules connect with external devices by terminal blocks in front of module. The module provides standard RS-485 serial communication interface. Each communication port has an indicator LED.

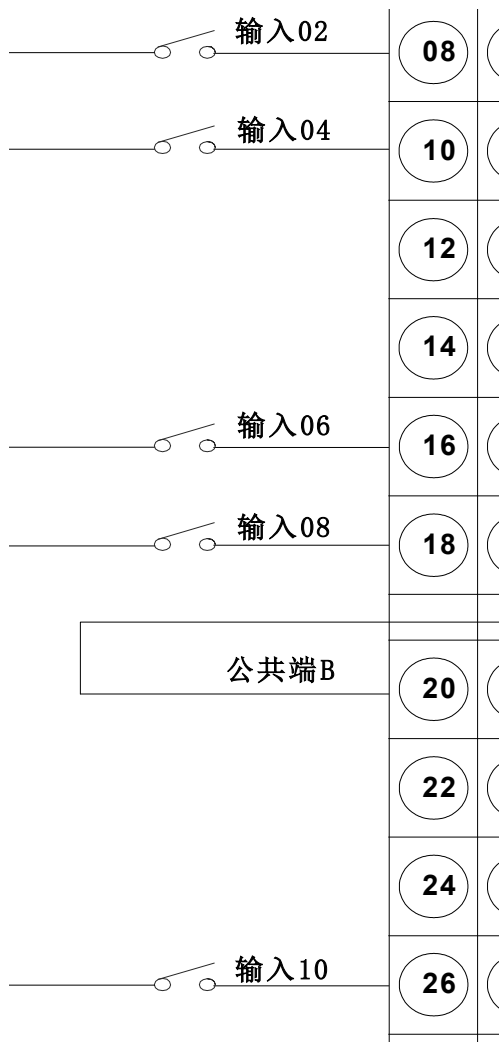

**CMM301-0401 Terminal wiring diagram**

## 7.2 Profibus DP Slave Communication Module

### CMM301-0103

#### Order Number

300CMM3010103

#### Features:

1. Standard PROFIBUS-DP slaver interface, DP-V0/V1, complying with IEC61158 and GB/T 20540-2006: the third part of “Digital data communication for measurement and control - Fieldbus for use in industrial systems”.
2. Baudrate can be set by user, and the maximum value is 12M bps
3. The amount of Slave station in Profibus system is up to 30
4. Supporting extend modules: less than 16(for 32-point DI or DO module), 7(for 16-point AI module) and 7(for 4-point AO module);
5. Intelligent module with self-diagnosis function can be reset and reboot automatically when fault, which enables the controller to be safer.
6. Overall LED indicator: run or fault states of power supply, module activation, module operation, or Profibus operation can all be indicated by LED indicators.
7. Hot plugging support.

**Outlook**

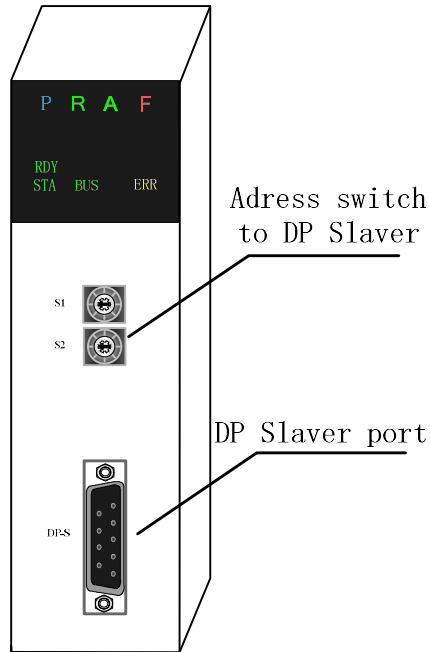

**CMM301-0103**

**Indicator LED description:**

The table below describes LED display indication and work status of DP slave communication module CMM301-0103.

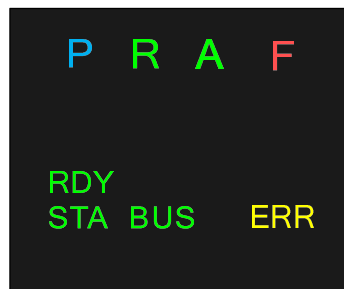

**Indicator LEDs**

LED	Color	State	Function
P	Blue	Light/ off	Power Supply normal / abnormal
R	Green	Flicker/ Constant Lighting	Run normally/ program is running but parameters are not loaded
A	Green	Light/ off	HIN work normally/ abnormally
F	Red	Light/ off	Fault/ Running normally
RDY	Green	Light/ off Flicker/Light	Main control exchanges data with profibus normally / abnormally
STA	Green	Light/ off	Correctly/not correctly received the configuration message from the master
BUS	Green	Flicker/ off	Communicate normally with slave/Communicate abnormally with slave
ERR	Yellow	off / Light	Diagnosable Fieldbus error / Running normally

**The working state corresponding to the indicator LED is as follows:**

- P: power supply indicator LED. It shows if the power supply is normal.
- R: Run indicator LED. When the module is running normal, the green LED flickers. If the green LED is always on, that means program has been running but parameter is unloaded.
- A: HIN Active Indicator LED. When HIN works normally, the LED is on, or it turns off.
- F: Fault Indicator LED. The LED is light when the module is fault.

- RDY: Main control exchanging data with Profibus indicator LED. When it blinks, data exchange goes normally. When it lights always or goes off, data exchange goes abnormally.
- STA: Slave Configuration Indicator LED. It goes on when receiving data correctly from the master
- BUS: Bus Communication Indicator LED. It lights always when the master could communicate normally with slave; and it goes off when the communication is abnormal.
- ERR: Bus Error Indicator LED. It lights always when a diagnosable Fieldbus error occurs; and it goes off when bus communication is normal.

### Technical Specification

CMM type	CMM301-0103
Order NO.	300CMM3010103
Power Consumption	2.0W/5V
Current Consumption	400mA/5V
Number of Communication Port	1
Type of the port	Standard PROFIBUS-DP slaver
Baud Rate	4800~12Mbps
Interface Isolation	optoelectronic isolator 2500V rms
Communication Program	GSD file supported by offer
Weight	220g
Dimensions W×H×D (mm)	40×145×158

### Hardware Setting and Communication Interface of CMM301-0103

#### 1. DP Slaver address switch

The module provides two decimal rotary address encoder switches S1 and S2.

The DP slave address is equal to  $S1*1+S2*10$ , which should be set correctly before power up.

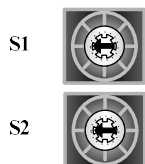

## 2. DP Communication port

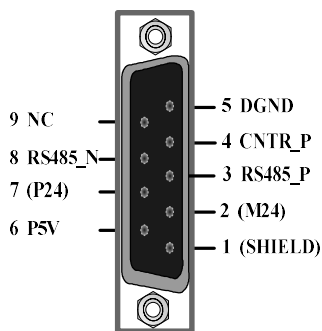

DP-S: standard SUB DB9 Female port, the pin definition is shown as follows:

NO.	Pin definition	NO.	Pin definition	NO.	Pin definition
1	[SHIELD] optional	4	CNTR_P	7	P24
2	[M24] optional	5	DGND	8	RS485_N
3	RS485_P	6	P5V	9	NC

Note: NC—NO CONNECTION.

With the physical and electric property limitation, Profibus could support at most 30 CMM301-0103 modules. Please pay attention to this limitation when configuring. If slave stations are more than 30, please add Profibus relay device.

## 7.3 Double CAN Module CMM301-0204

### Order Number

300CMM3010204

### Features:

1. Dual CAN interface, custom protocol communication.
2. Baud rate free programming configuration, supporting 5K-1000K basic baud rate.
3. The maximum input of internal communication is 120 words (240Bytes) , output is 120words (240Bytes) .
4. Intelligent module with self-diagnosis function can be reset and reboot automatically when fault, which enables the controller to be safer.
5. Overall LED indicator: power supply, module operation, fault, receiving and sending of CAN bus can be indicated by LED indicators.
6. Hot plugging support.

### Outlook

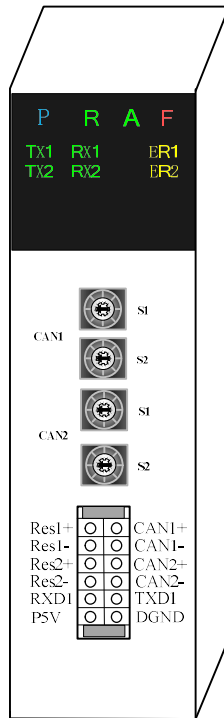

**CMM301-0204**

**Indicator LED description:**

The table below describes LED display indication and work status of Double CAN module CMM301-0204:

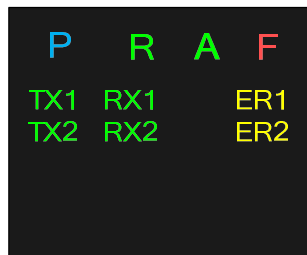

**Indicator LEDs**

LED	Color	State	Function
-----	-------	-------	----------

P	Blue	Light/ off	Power Supply normal / abnormal
R	Green	Flicker/Constant Lighting	Run normally/ program is running but parameters are not loaded
A	Green	Light/ off	HIN work normally/ abnormally
F	Red	Light/ off	Fault/ Running normally
TX1	Green	Light/ off	Indicator of CAN1 sending data,sending data is light/No data is sending, light is off.
RX1	Green	Light/ off	Indicator of CAN1 receiving data,receiving data is light / No data is receiving, light is off
TX2	Green	Light/off	Indicator of CAN2 sending data,sending data is light / No data is sending, light is off.
RX2	Green	Light/off	Indicator of CAN2 receiving data,receiving data is light / No data is receiving, light is off
ERR1	Yellow	Light/off	Indicator of CAN1 fault,constant lighting means communication can be diagnosable error, off means communication is normal.
ERR2	Yellow	Light/off	Indicator of CAN2 fault,constant lighting means communication can be diagnosable error, off means communication is normal.

**The working state corresponding to the indicator LED is as follows:**

- P: power supply indicator LED. It shows if the power supply is normal.
- R: Run indicator LED. When the module is running normal, the green LED flickers. If the green LED is always on, that means program has been running but parameter is unloaded.
- A: HIN Active Indicator LED. When HIN works normally, the LED is on, or it

turns off.

- F: Fault Indicator LED. The LED is light when the module is fault.
- TX1: Indicator of CAN1 sending data, sending data is light/No data is sending, light is off.
- RX1 Indicator of CAN1 receiving data, receiving data is light / No data is receiving, light is off.
- TX2: Indicator of CAN2 sending data, sending data is light / No data is sending, light is off.
- RX2: Indicator of CAN2 receiving data, receiving data is light / No data is receiving, light is off.
- ER1: Indicator of CAN1 fault, constant lighting means communication can be diagnosable error, off means communication is normal.
- ER2: Indicator of CAN2 fault, constant lighting means communication can be diagnosable error, off means communication is normal.

### Technical Specification

CMM type	CMM301-0204
Order NO.	300CMM3010204
Power Consumption	2.25W/5V
Current Consumption	450mA/5V
Number of Communication Port	2
Type of the port	CAN Master
Baud Rate	5~1000kbps
Interface Isolation	optoelectronic isolator 2500V rms
Weight	220g
Dimensions W×H×D (mm)	32×110×97

## Hardware Setting and Communication Interface of CMM301-0204

### 1. CAN module address switch

The module each CAN provides two decimal rotary address encoder switches as shown below. The above two dial switch can set CAN1 address, the address of CAN1 is equal to  $S1+S2*10$ , which should be set correctly before power up. The following two dial switches can set CAN2 address, the address of CAN2 is equal to  $S1+S2*10$ , which should be set correctly before power up.

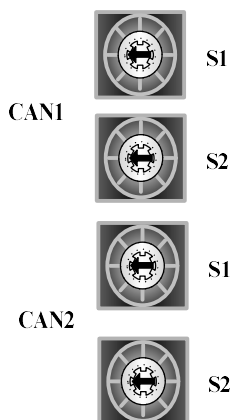

### 2. External interface

The external communication module adopts external 12-pin terminals, which are 2-way CAN interface, corresponding 120  $\Omega$  termination resistor interface and the underlying firmware download RS232 serial port, as defined below:

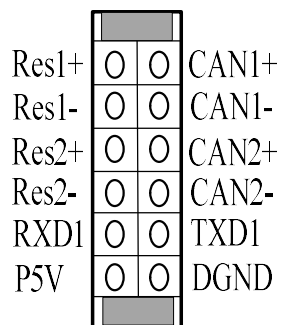

CAN1+、CAN1- and CAN2+、CAN2-: interface terminal of 2 way of CAN, access to the on-site CAN bus by shielded twisted pair.

Res1+、Res1- and Res2+、Res2-: There are two CAN interface terminating resistor enable terminals, for examples: Res1+、Res1- terminal vacancy. CAN1 has no 120  $\Omega$  terminating resistor; if the Res1+、Res1- terminals are shorted-cicruited, CAN1 internal 120  $\Omega$  termination resistor is enable.

TXD1, RXD1, DGND, P5V: Use the RS232 interface terminal to download the firmware of the bottom layer of the module. Use a dedicated serial cable to connect to the PC serial port (If the PC has no serial port, use a USB to serial port), and dial the K1 switch to the following position. Power off the module, and then power it on again to download the underlying firmware.

Note:Need a female DB9 and one of three wires shield (the three wire colors are gray,brown and black), three lines of gray, brown and black are welded to the DB9 female Pins 2, 3, and5, and then connect the DB9 female pin2, 3, 5 cables to module TXD1(gray),RXD1(brown) and DGND(black).

## 7.4 Ethernet Substation CMM301-0118

### Order Number

300CMM3010118

### Features:

1. Communication speed is 10/100Mbps adaptive.
2. IP conflict detection alarm.
3. Comprehensive LED indicator.
4. Hot plugging support.
5. The maximum data exchange capacity for each substation module is 1K for each

uplink and downlink.

- 6. Supports up to 2 backplanes (12 slots).
- 7. Support serial port module.
- 8. Two ring network ports have By-pass function.

**Outlook**

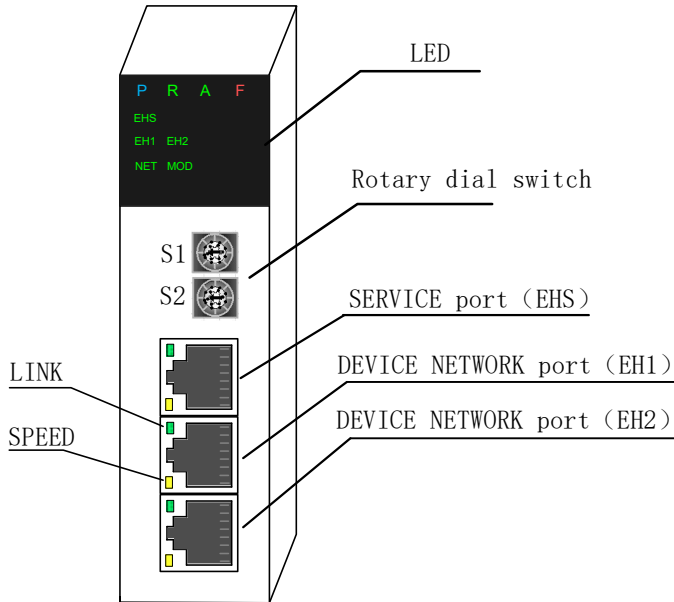

**CMM301-0118**

Mounting dimensions (width × height × depth): 32mm × 110mm × 97mm.

**LED indicator:**

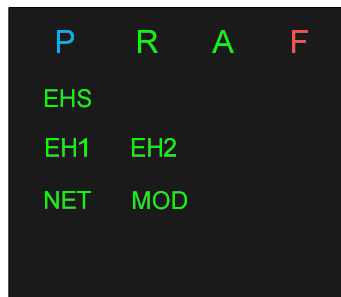

**Indicator LEDs**

The LED indicator is only on, off, or blinking (blinking means the indicator is on for

0.5 seconds, off for 0.5 seconds). The specific definitions are shown below.

CMM301-0118 Substation Indicator Meaning

LED	Color	State	Meaning
P	Blue	Constant Lighting/ off	Power on/ Power off
R	Green	Flicker/Constant Lighting	Run normally/ Program has been running but parameter is unloaded
A	Green	Constant Lighting/ off	Normal communication/disconnection between the IO module above the rack
F	Red	Light / off	Fault/ Running normal
EHS	Green	Constant Lighting/ off	Service port function is normal/abnormal
EH1	Green	Constant Lighting/ off	Daisy chain ring network port 1 function is normal/abnormal
EH2	Green	Constant Lighting/ off	Daisy chain ring network port 2 function is normal/abnormal
NET	Green	Constant Lighting	Normal communication with the master station
		Flicker	Abnormal communication with the master station
MOD	Green	Constant Lighting/off	This module's position dialing code has been changed / The module dialing code has not been changed, IP has no conflict
		Flicker	This module has conflicting IP

**The working state corresponding to the indicator LED is as follows:**

- P: Power indicator LED. When module power on ,the LED is on; When module power off ,the LED is off.
- R: Run indicator LED. When the module is running normal, the green LED flickers. If the green LED is always on, that means program has been running but parameter is unloaded.
- A: The indicator lights up when there is a normal communication between the substation module and the IO module on the rack, and the indicator is off when the communication with all IO modules is abnormal.
- F: Fault indicator LED. The indicator is off when the module runs normally. When the module is abnormal (usually the switch module is faulty or the module is not inserted in the corresponding backplane slot), the indicator lights up.
- EHS:Service port indicator. the indicator light is on after the network cable is plugged in to establish the link on the service interface, and the indicator is off when no link is established on the service interface.
- EH1: Ring network port 1 indicator. When the ring network port 1 function is normal, the indicator is on. When the ring network port 1 function is abnormal, the indicator is off.
- EH2: Ring network port 2 indicator. When the ring network port 2 function is normal, the indicator is on. When the ring network port 2 function is abnormal, the indicator is off.
- NET: Communication indicator LED, the indicator is on when the communication between the substation and the master station is normal, and the indicator is flashing when the communication is abnormal.
- MOD: Status indicator LED, the indicator is off when the substation module

works normally, the indicator is on when the substation dial code is changed but the module is not restarted, and the indicator flicker when there is the IP conflict between the substation module and the network.

RJ45 network port indicator as shown below:

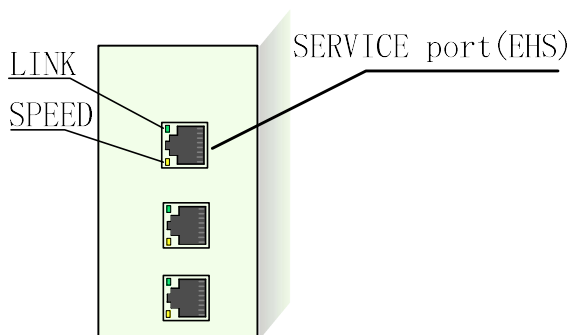

### RJ45 network port indicator

Three RJ45 network ports have their own indicators, which are LINK and SPEED lamps. The module LINK light is green and can be judged as 10Mbps or 100Mbps. The SPEED light is yellow and can represent the link status. The specific indications are as follows:

Table Indicators on the RJ45 network port

Name	Colour	Status	Indicator status meaning
LINK	Green	Light	100 Mbps link detected
		off	10 Mbps link detected
SPEED	Yellow	Light	Ethernet link detected
		Flicker	Data on the Ethernet link
		off	No data on the Ethernet link

### Technical Specification

Communication module type	CMM301-0118
Order number	300CMM3010118
Power consumption	<6W
Current consumption	<1.2A@5V
Physical interface	3 RJ45 ports (only 1 IP address)
Communication Port Protocol	Custom protocol, named NARING
Exchange mode	Full duplex
Maximum number of connections	16 Ethernet substations communication modules
Transmission rate	10/100Mbps
redundancy	Cable redundancy
Topology	Daisy Chain Ring Network
Transmission support media	Twisted pair
Logo	CE FCC
Power supply	Rack power supply
Weight	<1kg
Size Width × Height × Depth	32mm × 110mm × 97mm

### Hardware settings and external interfaces

#### 1. Service port function

This port supports the following modes (select by rotary dial switch)

- (1) Access port (module default state, dialing codes S1 and S2 are all set to 0):

This mode supports Ethernet communication, can access the module connected to the daisy chain ring network, and can also be used as the underlying software update interface of the master station ( The maintenance port function needs to connect the

CPU download network port to other service ports that are connected to the ring network module).

(2) Port mirroring (S1 is placed in F position, and S2 is arbitrary): In this mode, the data traffic of the other 2 ports is copied to this port, so that the connected tools can be used to monitor and analyze the port traffic.

Port mirroring feature can use Wireshark packet capture tool.

## 2. DEVICE NETWORK interface

RJ45 Interface: Provides connections for remote I/O communications, providing cable redundancy through a daisy-chained ring network architecture.

## 3. Module By-pass function

The two ring network ports of the CMM301-0118 module have a By-pass function. When the module is powered off, the By-pass function is triggered. The network skips this module. At this time, the two ring network ports connected to the module are physically implemented. The entire link will not cause the entire network to fail because of a power failure of one module.

The length of the communication between two sub-stations of By-pass cannot exceed 100m.

## 4. Set substation number

Before powering up the CMM301-0118 substation module and before downloading the application program, use the rotary dial switch on the front of the module to set the substation number of the Ethernet substation.

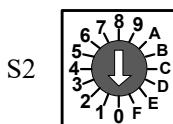
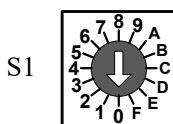

### **Set the substation number by dialing**

The substation module provides two hexadecimal rotary code switches S1 and S2, but the substation number only uses the lower 10 bits of S1 and S2 (S1 range is 0-9, S2 range is 0-9). The station number is calculated as:

$$\text{substation number} = S2 \times 10 + S1$$

Note:

- (1) The changed dialing value does not take effect until the module is restarted.
- (2) Live change of the dial code will activate the module's MOD indicator and an unmatched message will be recorded in the module diagnosis.
- (3) The effective value of substation number is 1-99 (decimal method).

### **5. The substation IP is set to 192.168.1.66 or 192.168.2.66**

In order to facilitate the diagnosis of the module, you can dial S1 to the E position (the dial code S2 is an arbitrary value), so that the substation module IP is set to 192.168.1.66; the dial code S1 is dialed to the D position (the dial code S2 is an arbitrary value), so that the substation module IP is set to 192.168.2.66.

When the dialing code S1 is dialed to the E position or the D position, the substation IP takes effect immediately and there is no need to restart the substation module.

## **7.5 Profinet Slave Communication Module CMM301-0109**

### **Order Number**

300CMM3010109

### **Features:**

NA300CMM301-0109 module is an interface module for connecting the NA300 IO module to the SIEMENS PLC system. The function is as follows:

1. Connect the NA300 IO module to the SIEMENS PLC system.

2. Connect the NA300 IO module through the backplane bus.
3. Connect the NA300 other communication modules through the backplane bus.
4. There are 2 RJ45 interfaces externally.
5. Support the following Ethernet services: ping, arp, network diagnostics.
6. Disable the port.
7. MRP
8. The shortest data refresh between PROFINET master and slave is 1ms.
9. Reset the module through the network port to factory settings.
10. Support remote firmware update.

## Outlook

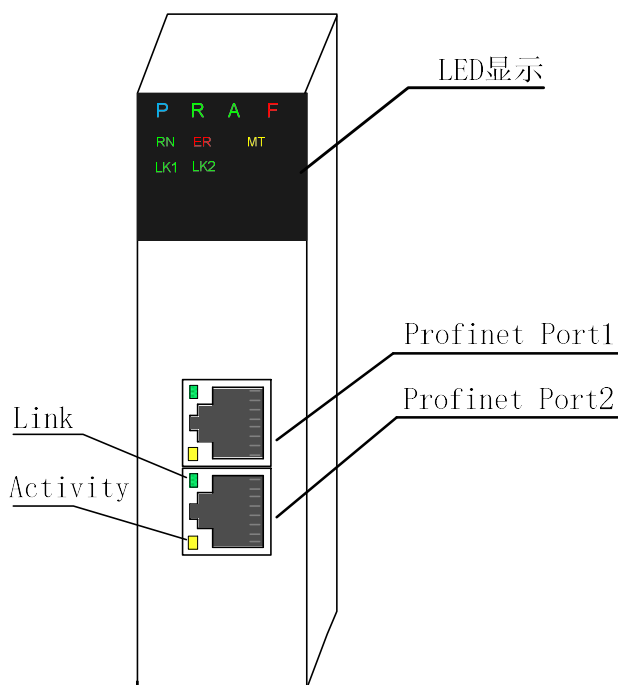

**CMM301-0109**

### Indicator LED description:

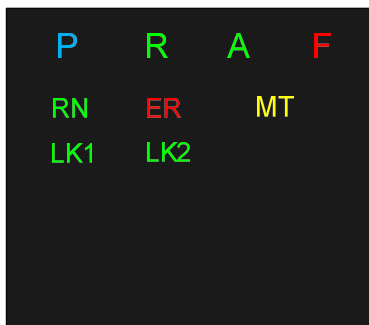

**Indicator LEDs**

The LED indicator is only on, off, or flicker (flashing means the indicator is on for 0.5 seconds, off for 0.5 seconds).

**1.Indicator LED of P/R/A/F**

LED	Color	State	Function
P	Blue	Light	Power Supply normal
		Off	Power Supply abnormal
R	Green	Flicker	Run normally
		Off	Program is running but parameters are not configured
A	Green	Light	HIN work normally
		Off	HIN work abnormally
F	Red	Light	Fault
		Off	Run normally

**2.Indicator LED of PN/ER/MT**

LED			Function
RN(RUN) Green	ER(Fault) Red	MT(maintain) Yellow	
Off	Off	Off	Power Supply abnormal
			LED test during start up: 3 LED indicators light up for approximately 0.5 seconds at the same time.
Flicker	Off	Off	Disable the interface module
			Interface module is not configured
			Module is running

			Interface module is configured
			Module reset to factory settings
Light	Irrelevant	Irrelevant	The module is in data exchange with the IO device.
Irrelevant	Flicker	Irrelevant	The configured architecture does not match the actual architecture of the module
			There is a parameter error in the I/O module
Irrelevant	Irrelevant	Light	The module needs maintenance
Flicker	Flicker	Flicker	"Node flash test" has been run (The LK1 and LK2 LED indicators of the PROFINET interface also flash)
			The module slot number is incorrect (The PROFINET module is not inserted in slot 1 and the LK1 and LK2 indicators are not blinking)
Flicker	Light	Off	PN slave and master or slave and slave disconnected
Light	Light	Off	IO device with PN slave has self-diagnosis failure

### 3.Indicator LED of LK1/LK2

LED	Color	State	Function
LK1	Green	Light	The module has an Ethernet connection to the external P1R network port
		Off	The module has no Ethernet connection to the external P1R network port
		Flicker	"Node flash test" has been run( The RN/ER/MT LED indicators of the PROFINET interface also flash)
LK2	Green	Light	The module has an Ethernet connection to the external P2R network port
		Off	The module has no Ethernet connection to the external P2R network port
		Flicker	"Node flash test" has been run( The RN/ER/MT LED indicators of the

			PROFINET interface also flash)
--	--	--	--------------------------------

#### 4. Indicator LED of external network port

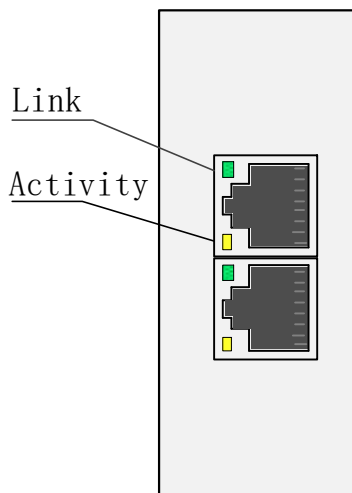

LED	Color	State	Function
LINK	Green	Light	100M link detected
		Off	10M link detected
ACTIVITY	Yellow	Light	Link is connected but no data
		Flicker	Link is connected and data is normal

#### External network port

The module provides two external RJ45 ports. Port 1 and Port 2 are functionally equivalent. The RJ45 port has Automatic MDI/MDI-X function, which means the network port supports auto-flip function (Automatic MDI/MDI-X function refers to normal communication with the NA300CMM301-0109 using both straight-through and crossover wires. The specific definition of the port is as follows.

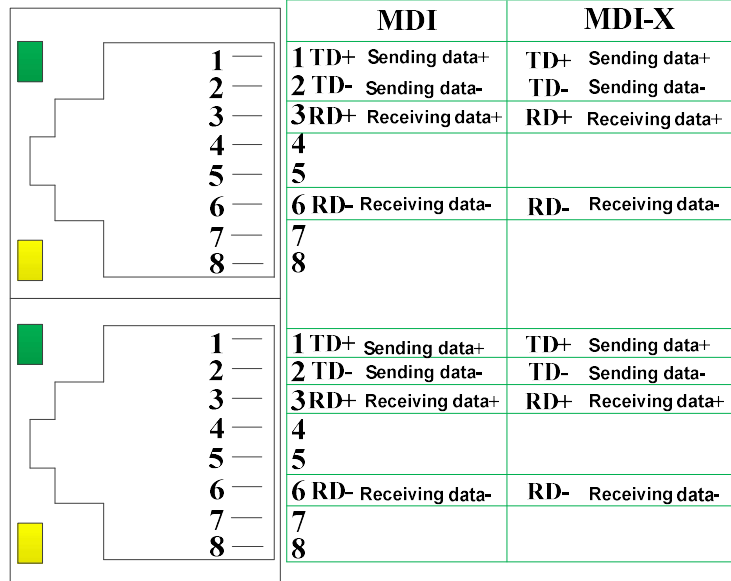

### Technical Specification

CMM type		CMM301-0109
Order NO.		300CMM3010109
Power Consumption		<5.0W
Current Consumption		<1A@5V
Physical interface	Number of communication port	2
	Type of the Port	RJ45
	Transmission mode	PROFINET,100 Mbit/s,Full duplex(100BASE-TX)
	10 Mbit/s	Yes,Suitable for Ethernet services
	100 Mbit/s	Yes,PROFINET,100 Mbit/s,Full duplex(100BASE-TX)
	Auto-negotiation	Yes
	Automatic crossover	Yes
Maximum Slave Stations		Depends on the master station
IO Points		512 byte
Transmission distance		100m(Distance between stations)
Topology		Ring type, Line type, Star type

## NA300 Series Programmable Logic Controller Technical Specifications and User Manual

Transmission support media	PROFINET connector and PROFINET cable
Communication Program	Programmable mode
Operating temperature	-15℃-55℃
Power supply	Rack power
Weight	<1kg
Dimensions W×H×D (mm)	32mm×110mm×97mm

## 7.6 CANOpen Master Module CMM 301-0104

### Order Number:

300CMM 301-0104

### Features:

- Complete communication tasks independently, both with NA300PLC/NJ300PLC Data exchange, also with CANOpen slave data exchange.
- A separate intranet is used for data exchange with NA300PLC/NJ300PLC module, which is separated from the intranet of I/O module to reduce the burden of intranet communication
- Compliant with CANopen standard protocol DS301v4.02
- Support NMT Master service
- Error Control: Support Heartbeat /Node Guarding Protocol
- Number of communication nodes: maximum 127 nodes (including the master station, the master station is node 0)
- Support for PDO services:
  - The maximum data size of RxPDO is 1024 bytes, and the maximum data size of TxPDO is 1024 bytes
  - Up to 4 TxPDOs and 4 RxPDOs can be configured per slave
  - PDO mapping: each PDO can map up to 32 parameters, but the total cannot exceed 8 bytes
- Support SDO service
- Support Emergency Protocol and display it in the configuration software window
- Support synchronization signal generation (SYNC producer , range 0-65535ms)
- As the NACANopenBuilder configuration software, the network can be configured directly through the CANOpen master module

- Comprehensive LED indication function
- The configuration parameters will not be lost when the power is turned off. After the power is turned on, the CPU will automatically load the parameters.
- Support hot swap

**Outlook:**

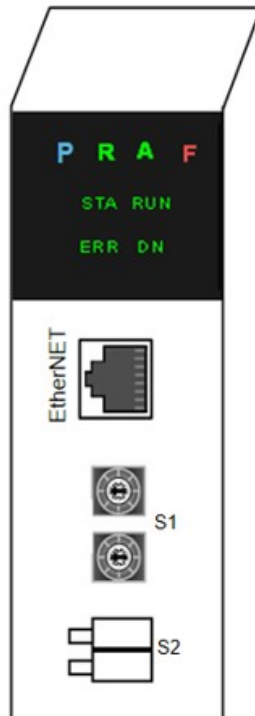

**CMM301-0104 Communication Module**

**LED indicator:**

The following table describes the serial communication module **CMM301-0104 led**

Display area indicator lights and their working status:

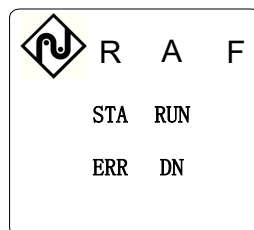

**LED \_ Display area indicator**

LED	Color	Status	Meaning
R	green	flashing / constant light	Module normal operation / module failure
A	green	ON/OFF	The module is sending data normally in the internal network /sending data abnormally
F	red	ON/OFF	The light is on to indicate that the module is faulty / the light is off during normal operation
STA	green		keep the lights
RUN	green	flashing / constant light	Main module running light , flashing when fault / always on when normal
ERR	green	ON/OFF	light is on when the main module is faulty/off when it is normal
DN	green	ON / OFF	Communication light with the slave station, on when all the slave stations communicate normally/off when the slave station fails

The specific meanings of the indicators on the module panel corresponding to their working status are as follows:

- 1) When all slave stations are offline, the RUN light will flash, the ERR light will be on, and the DN light will be off
- 2) When some slave stations are online, the RUN light is on, the ERR light is on, and the DN light is off
- 3) When all slave stations are online, the RUN light is on, the ERR light is off, and the DN light is on

And the master-slave communication status can only be monitored when the slave heartbeat function (ie heartbeat message monitoring) is configured. If it is not configured, the slave is not online by default.

- 4) When the master module has no slave configuration, ERR flashes quickly

## Technical Specifications

Model	300CMM301-0104
order number	300CMM311-0104
Power consumption	3.0W/5V
current consumption	600mA/5V
Number of communication ports	1
Interface Type	6-pin open CANOpen connector, CAN interface
Support common baud rate	50kbps, 100kbps, 125kbps, 250kbps, 500kbps, 800kbps, 1Mbps
type of information	I/O polling
weight	250g
Dimensions (W×H×D) (mm)	40×145×158

## Module hardware setting and external interface of 300 CMM 301-0104

### 1. Debug serial port

The module provides an RJ45 interface for updating the code .

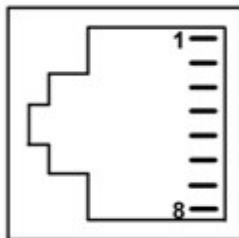

### 2 . Communication Interface

The external communication of the module uses a 6-pin open connector to access the on-site CANOpen bus, and at the same time has a RS232 interface for CANOpen configuration download.

The ports are defined as follows:

CANH	RXD
CANL	TXD
EARTH	GND

**3. address dial**

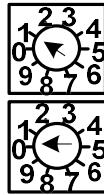

The address dialing code is not used yet, the default address of the master station is 0

**4. function dial**

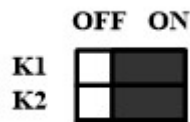

Dial code reserved for use

## 8 NA300 System Configuration

### Synopsis

NA300 intelligent programmable controller provides flexible system configuration, in which I/O module includes local I/O and remote I/O. Because different types of NA300 PLC modules can be fixed in any position of the backplane, flexibility of system configuration is greatly improved. To build a NA300 system, CPU module, I/O modules, backplane, wiring cable and relay accessories need to be selected. This chapter will introduce how to choose them.

### Content

Section	Content
7.1	Calculate I/O points, and choose I/O modules
7.2	Make out system solutions and choose CPU
7.3	Choose backplane and accessories

### 8.1 How to choose I/O modules

Before system configuration, you may calculate the number of I/O points according to the practical application at first. Final number of I/O points is the number you calculated multiplied by 1.1-1.2. This may facilitate expansion.

Table 1 I/O type (Choose according to the number of points and types of modules)

Type	Order NO	Specifications	Remarks
Digital input module	300DIM3011601	DI16×DC24V	Sink and Source
	300DIM3013201	DI32×DC24V	Sink and Source
Digital output	300DOM3011601	DO16×DC24V×Transistor	Source

module	300DOM3013201	DO32×DC24V×Transistor	Source
SOE module	300IIM3011601	IIM16×DC24V	Sink and Source
	300IIM3013201	IIM32×DC24V	Sink and Source
Analog input module	300AIM3010401	AI4×current/voltage×Single-ended input	0~20mA -10V~10V
	300AIM3010801	AI8×current/voltage×Single-ended input	0~20mA -10V~10V
	300AIM3010405	AI4×RTD	
	300AIM3010805	AI8×RTD	
Analog output module	300AOM3010201	AO2×current/voltage	0~20mA -10V~10V
	300AOM3010401	AO4×current/voltage	0~20mA -10V~10V

## 8.2 How to choose CPU

The system integration solution must be taken into consideration when making the choice of CPU. Questions will be clarified in this integration solution, whether PLC will communicate with external devices and how, whether the communication requires monitor and whether single CPU with single network or dual CPU with dual network will be used.

**When choosing CPUs, the questions you must think about are shown as follows:**

- Do you need NIC, single network or dual network?
- Single CPU system or Dual CPU system?
- Basic CPU or High Performance CPU?

- Memory size of CPU.
- Maximum I/O points of CPU.

**Calculation of CPU's Memory size:**

Memory size is the size of hardware memory unit in PLC, while program size is the size used in a memory unit to store user program. Therefore, program size is usually smaller than memory size. Before the program is debugged, program size is unknown in the design phase. So we always use an estimated memory size instead of program size for choosing modules. Estimation of memory size has no settled formula. Many documents give different formula. In general, it can be estimated by the sum of 10 to 15 times of digital I/O points and 100 times of analog I/O points. The result can be regarded as a total number of words of memory size (16 bit/ word). And 25% margin should be considered based on the result.

Table 2 Types of CPU

Type	Order No	Explanation
Normal CPU	300CPU3010101	Normal CPU,RS485×2, standard MODBUS, 2 Ethernet interface(standard MODBUS/TCP), Memory size 8M

## 8.3 How to choose backplane

### 8.3.1 Backplane type

NA300 PLC backplane has two different types: eight-slot and twelve-slot. The number of backplane should be chosen according to the number of I/O modules calculated.



8-slot



12-slot

### 8.3.2 Main features of backplane

- **Configuration:** There must be a main backplane when we design a system. The backplane on which the CPU module is mounted is regarded as the main backplanes. Expansion backplanes(12 at most) are needed when there are many modules. All backplane are connected by bus expansion cable.
- **Slot:** A backplane offers 8~12 slots with standard width. Each module occupies one slot.

- **Backplane address:** There is a rotary switch on each backplane used to set its address as 0~7(8-F unused).



- **Module address:** Module address is decided by the module's backplane address and slot number. The slot number of each backplane is 1~12 in turn from left to right. The formula of calculating module address is:

$$\text{Module address} = \text{Backplane address} \times 15 + \text{slot number}$$

### 8.3.3 Bus Expansion

In the multi-backplane(module backplane) system, a bus expansion cable is used to connect these backplanes. One side of the cable connects to the downward connector of bus interface in upper backplane, another side connects to upwards connector of bus interface in lower backplane, and the last expansion backplane only connect with the upper. The interface of the main backplane and the last expansion backplane that connects downward should be mounted with a bus terminal adapter.

Table 3 Related Accessories:

Order No.	Accessories	Remarks
300BKM3010801	8-slot backplane	
300BKM3011201	12-slot backplane	
300CNL001-0010	Bus Expanding Cable, 1m	
300CNL001-0020	Bus Expanding Cable, 2m	
300CNL001-0030	Bus Expanding Cable, 3m	

NA300 Series Programmable Logic Controller Technical Specifications and User Manual

300NUL3010101	Null module	
300BUS3010101	Bus terminal adapter	
300CNE3013601	36-core module connection terminal - with release lever	
300CNE3013602	36-core module connection terminal - screw fixed	
300CNE3011801	18-core module connection terminal - with release lever	
300CNE3011802	18-core module connection terminal - screw fixed	
300CNE3012601	26-core module connection terminal - with release lever	
300CNE3012602	26-core module connection terminal - screw fixed	
300CNE3011301	13-core module connection terminal - with release lever	
300CNE3011302	13-core module connection terminal - screw fixed	
300CNE3011201	12-core module connection terminal - with release lever	
300CNE3011202	12-core module connection terminal - screw fixed	
300CNE3010601	6-core module connection terminal - with release lever	
300CNE3010602	6-core module connection terminal - screw fixed	

	terminal - screw fixed	
--	------------------------	--

Main plugbox

Bus Terminal



Expansion plugbox I



Bus Terminal

Expansion plugbox II

# 9 Hardware Mounting

## □ Synopsis

CPU module, power supply module and I/O module of NA300 PLC are always fixed to the backplanes, and the backplanes are fixed to the cabinets. This chapter introduces the installation size of holes and the right way to fix modules and backplanes.

## □ Content

Section	Content
8.1	The Mounting of Module Backplane
8.2	The Mounting of Module

## 9.1 The Mounting of Module Backplane

The module backplane can be mounted in a cabinet. The mounting holes on the backplane are used to fix the module backplane. The mounting size of 8-slot and 12-slot module backplanes are shown in the following figures (unit mm):

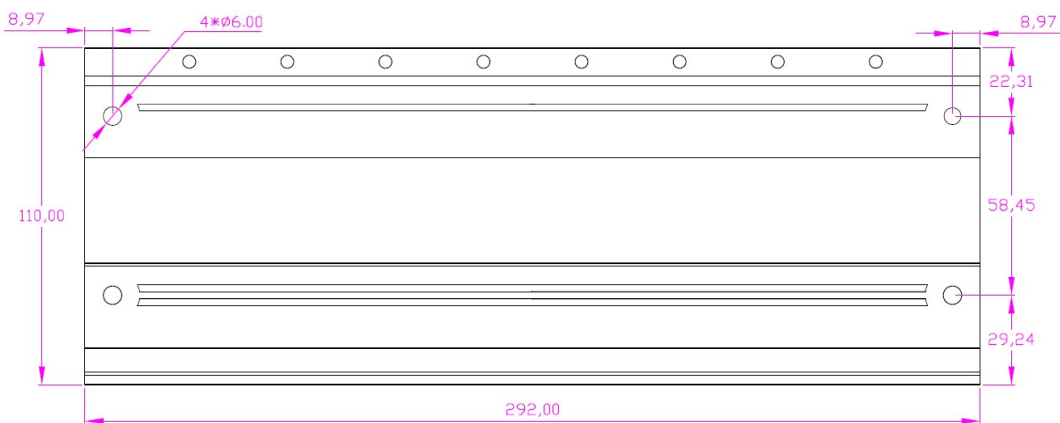

**Hole dimension on 8-slot backplane**

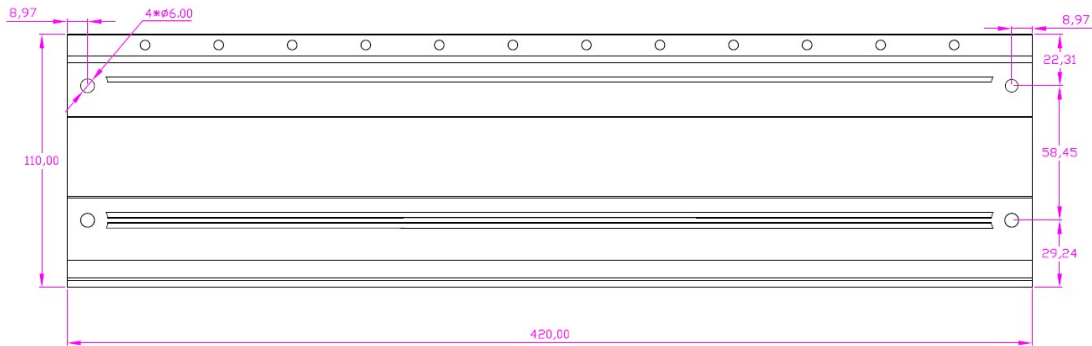

Hole dimension on 12-slot backplane

## 9.2 Mounting of the module

### ■ Mounting position of the module

NA300 intelligent PLC has no restrictions in the mounting slots for the different types of modules. Based on the real application requirements, users can set module type for each slot in the NAPro software. All modules, including power supply module and CPU module, can be mounted in any slot position.

### ■ Confirmation of the module type

Before mounting, please ensure that the module type is the same with the slot module type in the database configuration.

### ■ Mounting of Module

#### Step A:

Please slide the module slowly from top to bottom along the slot direction of the backplane.

#### Step B:

Move the module to the bottom, the top of the module to the aluminum clip

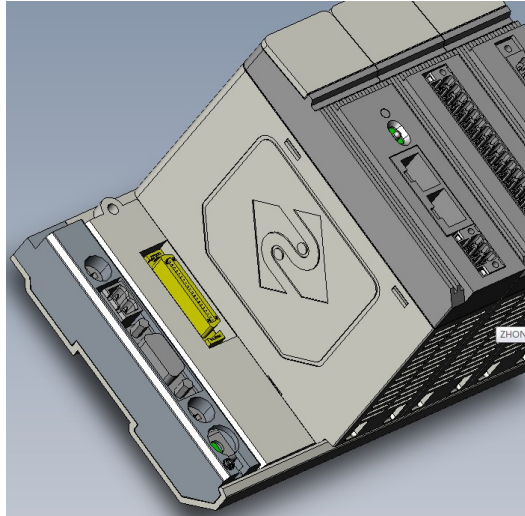

**Step C:**

Press the module down so that the module is fully in contact with the connector on the backplane while ensuring that the module's fastening screw can be inserted into the threaded hole in the backplane.

Note: When the module is pressed downwards, if the resistance is too large, it means the module does not jam the buckle below, and then push the module to continue to move downwards.

**Step D:**

Tighten the fastening screw.

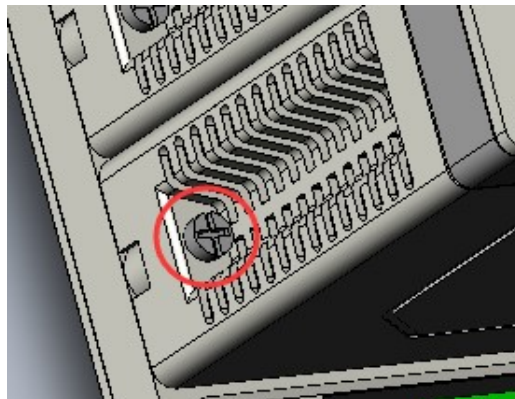

## 10 Accessories

Related accessories of NA300 PLC that need to order separately are listed as below:

NA300 PLC Accessories	Description	Order no
8-slot backplane		300BKM3010801
12-slot backplane		300BKM3011201
Bus expansion cable, the length is 1.0m	Choose the length according to the practical application	300CNL3010101
Bus expansion cable, the length is 2.0m		300CNL3010201
Bus expansion cable, the length is 3.0m		300CNL3010301
Null module	The dimensions similar to DI,DO,AI modules	300NUL3010101
Bus terminal adapter	The head and tail backplane of every PLC require one respectively, total two adapters are needed.	300BUS3010101
36-core module connection terminal - with release lever	Choose the type according to 32-point IO module	300CNE3013601
36-core module connection terminal - screw fixed	Choose the type according to AIM301-0801 Choose the type according to AIM301-0805 Choose the type according to	300CNE3013602

NA300 Series Programmable Logic Controller Technical Specifications and User Manual

	AOM301-0401		
18-core module connection terminal - with release lever	Choose the type according to 16-point IO module Choose the type according to AIM301-0401 Choose the type according to	300CNE3011801	
18-core module connection terminal - screw fixed	AIM301-0405 Choose the type according to AOM301-0201	300CNE3011802	
26-core module connection terminal - with release lever	Choose the type according to	300CNE3012601	
26-core module connection terminal - screw fixed		300CNE3012602	
13-core module connection terminal - with release lever		CMM301-0401	300CNE3011301
13-core module connection terminal - screw fixed			300CNE3011302
6-core module connection terminal - with release lever		Choose the type according to CPU	300CNE3010601
6-core module connection terminal - screw fixed	300CNE3010602		

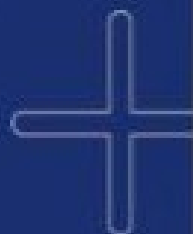
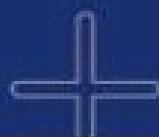
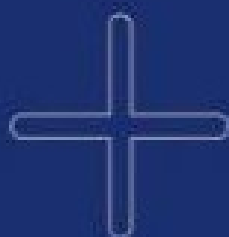

南大傲拓科技江苏股份有限公司

江苏省南京市江宁经济开发区  
清水亭西路 199 号

199 Qingshuiting West Road,  
Jiangning Development Zone, Nanjing, China

TEL (86)(25) 68530188

FAX (86)(25) 68530178

[Http://www.nandaauto.com](http://www.nandaauto.com)